

OREC

PARTS CATALOG

SUPER FRESH "PICO"

26 MAI 1999

SF50

MODEL	PARTS CODE
SF50	80-1260-Δ Δ Δ-00

« CONTENTS »

FIG 1	HANDLE-----	1
FIG 2	CHANGE LEVER-----	3
FIG 3	TRANSMISSION-----	5
FIG 4	TRANSMISSION (SHAFT & DIFFERENTIAL GEAR)---	7
FIG 5	ENGINE BASE & TIRE-----	9
FIG 6	BELT COVER-----	11
FIG 7	ROTARY COVER-----	13
FIG 8	ROTARY & RESISTANT BAR-----	15

MAY 1999
TECHNO GREEN LTD.

FIG. 1 HANDLE

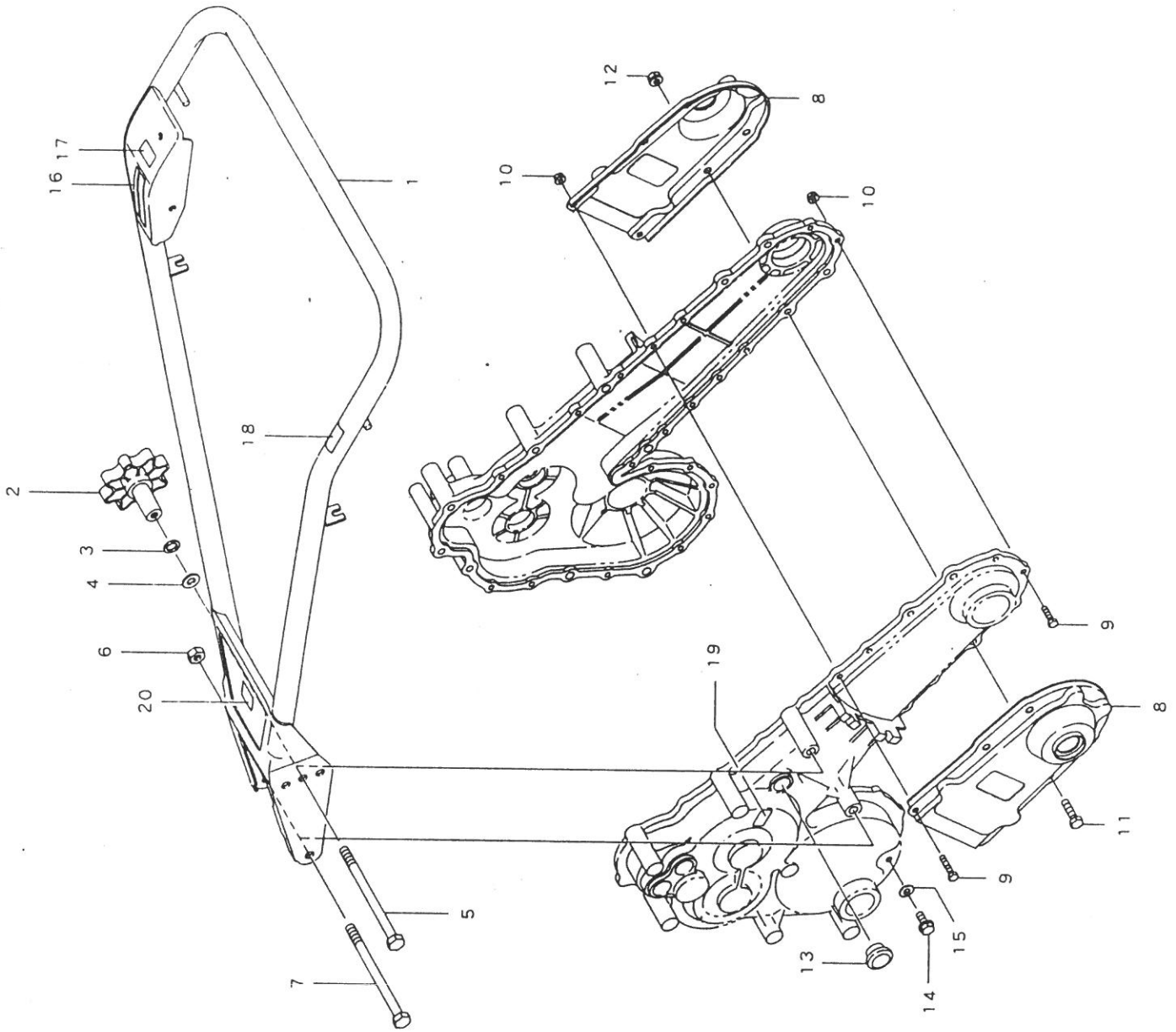

FIG. 1 Handle

Ref.	Parts No.	Parts Name	Qty	Ex-works	Remarks
1	80-1260-221-00	Handle	1	¥4,356	
2	80-1260-228-00	Knob Nut M10	1	¥195	
3	89-1750-100002	Spring Washer 10	1	¥5	
4	89-1713-100002	Flat Washer 10	1	¥7	
5	89-1113-101402	Hexagonal Bolt(8T) M10*140	1	¥302	
6	89-1551-100002	U Nut M10	1	¥32	
7	89-1113-101352	Hexagonal Bolt(8T) M10*135	1	¥249	
8	80-1260-751-00	Protection Cover	2	¥924	
9	89-1113-060252	Hexagonal Bolt(8T) M6*25	20	¥8	
10	83-1712-194-00	Terminal Nut M6	20	¥7	
11	89-1113-080302	Hexagonal Bolt(8T) M8*30	2	¥15	
12	89-1541-080002	Hexagonal Nut(SW) M8	2	¥11	
13	83-1110-683-00	Oil Cap 20	1	¥365	
14	89-1251-080002	Hexagonal Bolt M8*12	1	¥20	
15	83-1415-348-00	Packing 8.5*16*1.3	1	¥19	
16	80-1482-906-00	Label, Differential Lock	1	¥176	
17	80-1260-929-00	Label, Engine Switch	1	¥51	
18	80-1260-907-00	Main Clutch Mark	1	¥53	
19	83-1260-928-00	Label, Oil Quantity 2.5	1	¥21	
20	83-1516-915-00	Label, Caution 18	1	¥16	

FIG. 2 CHANGE LEVER

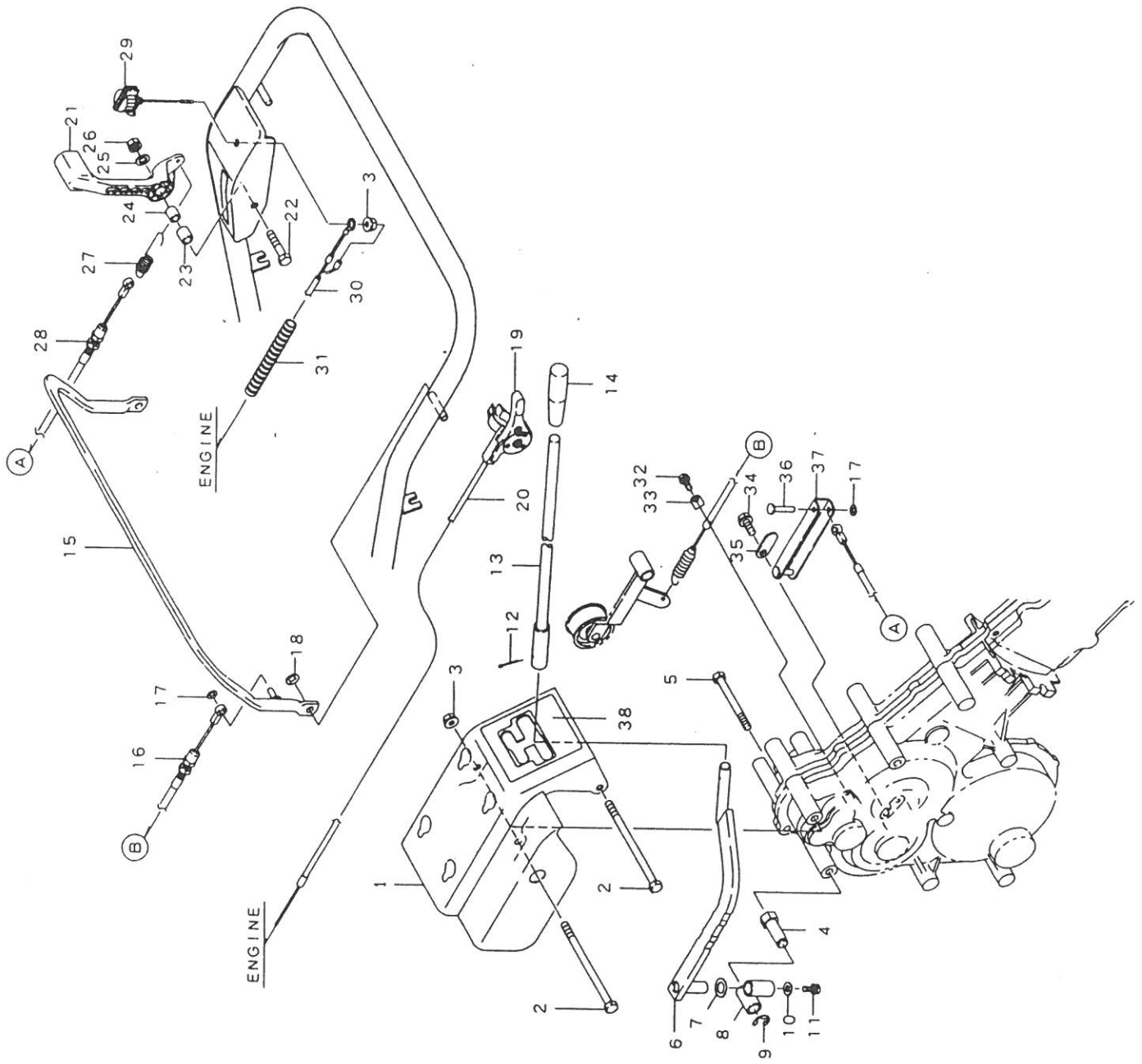

FIG. 2 Change Lever

Ref.	Parts No.	Parts Name	Qty	Ex-works	Remarks
1	80-1260-262-10	Gear Change Guide	1	¥2,667	
2	89-1251-081303	Bolt, Flange M8X130	2	¥147	
3	83-1310-191-00	Nut, Flange M8	3	¥8	
4	80-1260-535-00	Tension Arm	1	¥157	
5	89-1113-080802	Hexagonal Bolt(8T) M8*80	1	¥92	
6	80-1260-263-10	Change Lever	1	¥1,384	
7	83-1754-329-00	Washer 13*22*1.0	1	¥9	
8	80-1260-266-00	Change Lever Boss	1	¥194	
9	89-2521-000100	E-Type Stopper 10	1	¥8	
10	89-1713-060002	Washer 6	1	¥3	
11	83-1515-112-00	Hexagonal Bolt(SW) M6*14	1	¥16	
12	89-2120-300252	Pin 3*25	1	¥3	
13	80-1260-264-00	Change Lever Arm	1	¥573	
14	83-1711-426-00	Lever Grip 12	1	¥70	
15	80-1260-253-00	Clutch Lever	1	¥830	
16	83-1260-931-10	Main Clutch Wire	1	¥552	
17	83-1515-177-00	Push Nut 6	2	¥4	
18	83-1020-177-00	Push Nut 8	2	¥7	
19	83-1260-461-00	Throttle Lever	1	¥373	
20	83-1415-951-00	Throttle Wire	1	¥220	
21	80-1022-260-00	Differential Lock Lever	1	¥517	
22	89-1113-080402	Hexagonal Bolt(8T) M8*40	1	¥25	
23	80-1260-234-10	Differential Lock Lever Collar	1	¥59	
24	80-1020-270-00	Inner Collar	1	¥44	
25	89-1713-080002	Washer 8	1	¥5	
26	89-1541-080002	Hexagonal Nut(SW) M8	1	¥11	
27	80-1020-967-00	Change Spring	1	¥76	
28	83-1260-937-10	Differential Lock Wire	1	¥415	
29	80-1260-281-00	Engine Stop Switch	1	¥527	
30	80-1260-288-10	Engine Stop Wire Harness	1	¥522	
31	80-1260-225-00	Tube 10-200L	1	¥35	
32	83-1020-148-00	Hexagonal Tap Tight M6*14	1	¥11	
33	80-1515-186-00	Wire Holder	1	¥100	
34	80-1020-719-00	Hexagonal Tap Tight M8*18	1	¥28	
35	80-1260-276-00	Differential Lock Arm Holder	1	¥70	
36	89-2181-060307	Flat-Headed Pin 6*30	1	¥7	
37	80-1260-275-00	Differential Lock Arm	1	¥179	
38	80-1260-911-00	Label, Change	1	¥111	

FIG. 3 TRANSMISSION

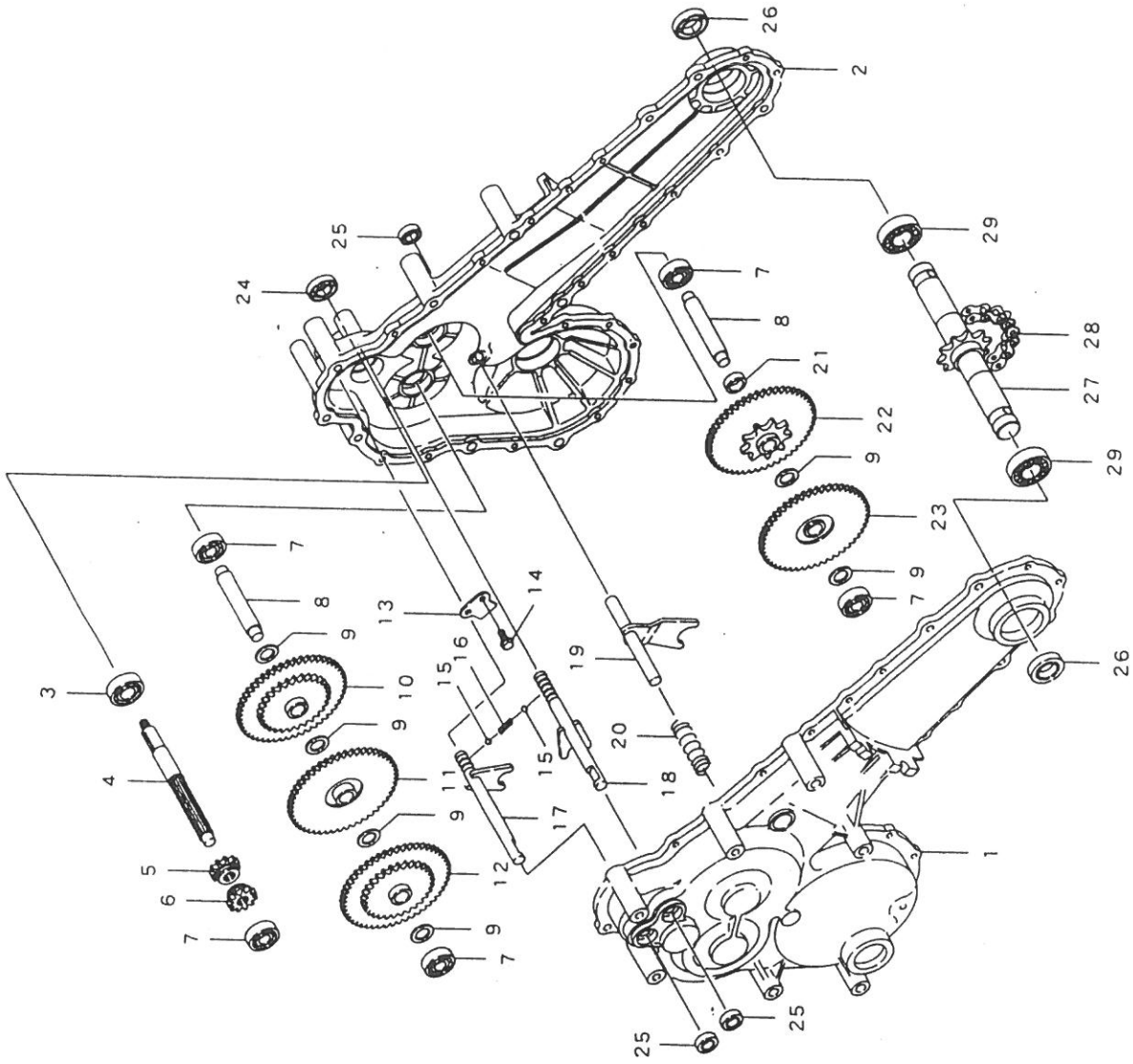

FIG. 3 Transmission

Ref.	Parts No.	Parts Name	Qty	Ex-works	Remarks
	80-1260-100-00	Gear Case ASSY	1	¥63,456	See Note 1
1	80-1260-101-00	Gear Case (L)	1	¥5,339	
2	80-1260-103-00	Gear Case (R)	1	¥5,280	
3	89-3111-062024	Bearing 6202	1	¥259	
4	80-1260-118-00	Main Shaft	1	¥2,185	
5	80-1260-122-00	Rotary Shift Gear 11T	1	¥692	
6	80-1260-120-10	Shift Gear 11T	1	¥425	
7	89-3111-062014	Bearing 6201	5	¥128	
8	80-1260-127-00	Shaft	2	¥587	
9	83-1020-361-00	Thrust Washer 15*24*1	6	¥32	
10	80-1260-131-30	Second Shaft 20T Rotary	1	¥4,362	
11	80-1260-129-10	Second Shaft Sprocket 9T	1	¥3,561	
12	80-1260-128-20	Second Shaft 20T	1	¥5,057	
13	80-1260-161-00	Shift Spring Holder	1	¥61	
14	83-1020-148-00	Hexagonal Tap Tight M6*14	2	¥11	
15	89-3410-060000	Ball 6	2	¥10	
16	80-1805-160-00	Shift Spring	1	¥73	
17	80-1260-110-20	Rotary Shift Folk Shaft	1	¥783	
18	80-1260-107-00	Main Shift Folk Shaft	1	¥807	
19	80-1260-116-00	Differential Lock Folk Shaft	1	¥405	
20	80-1260-117-00	Spring	1	¥56	
21	80-1260-139-10	Shaft Collar	1	¥53	
22	80-1260-136-30	Third Shaft Sprocket 9T	1	¥6,213	
23	80-1260-135-20	Third Shaft 12T	1	¥5,119	
24	89-5121-153007	Oil Seal UE 15.30.7	1	¥147	
25	89-5121-122207	Oil Seal UE 12.22.7	3	¥72	
26	83-1260-655-00	Oil Seal AP 30.45.8	2	¥427	See Note 2
27	80-1260-641-00	Rotary Shaft	1	¥1,865	
28	89-6513-520060	Chain #520-60L	1	¥1,005	
29	89-3111-060054	Bearing 6005	1	¥202	

Note 1: Gear Case ASSY contains the parts 1-29 of this page
and 1-17 of next page.

Note 2: No.537267~

FIG. 4 TRANSMISSION (AXLE & DIFF. GEAR)

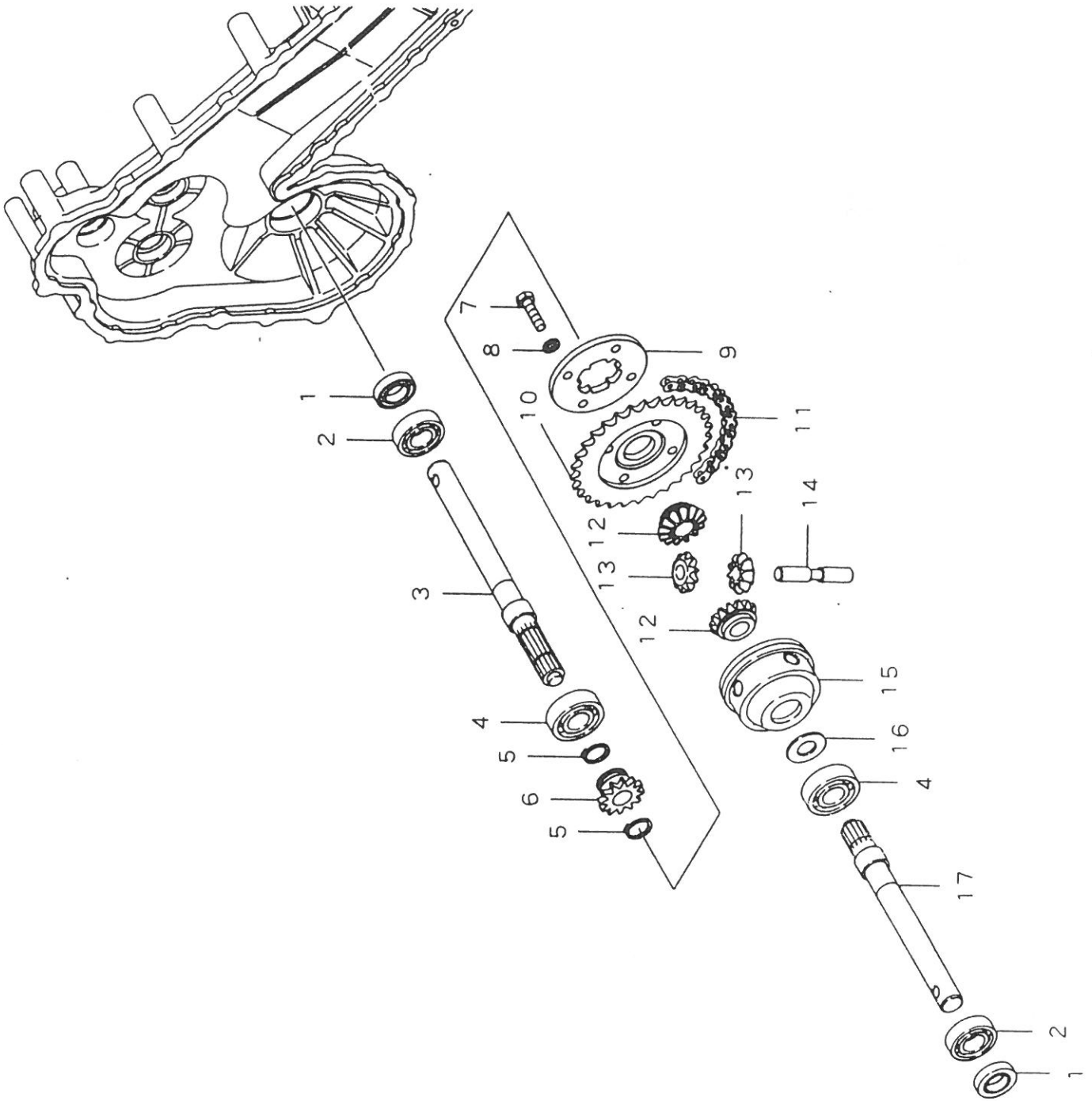

FIG. 4 Transmission(Shaft& Differential Gear)

Ref.	Parts No.	Parts Name	Qty	Ex-works	Remarks
1	89-5121-203508	Oil Seal UE 20.35.08	2	¥360	
2	89-3111-060044	Bearing 6004	2	¥347	
3	80-1260-147-00	Shaft (R)	1	¥4,773	
4	89-3111-062044	Bearing 6204	2	¥191	
5	89-2511-000200	Shaft Stopper 20	2	¥11	
6	80-1260-148-00	Differential Clutch On	1	¥1,109	
7	89-1113-080252	Hexagonal Bolt(8T) M8*25	4	¥14	
8	89-1750-080002	Washer 8	4	¥5	
9	80-1260-156-00	Differential Clutch Men	1	¥270	
10	80-1260-154-00	Shaft Sprocket 30T	1	¥3,508	
11	89-6513-420042	Chain #420-42L	1	¥587	
12	80-1260-152-00	Differential Gear 14T	2	¥1,115	
13	80-1260-153-00	Pinion 10T	2	¥792	
14	80-1260-155-10	Differential Pinion Shaft	1	¥249	
15	80-1260-151-00	Differential Case	1	¥994	
16	83-1310-371-00	Thrust Wahser 20*30*1	1	¥35	
17	80-1260-146-00	Shaft (L)	1	¥3,409	

FIG. 5 ENGINE BASE & TIRE

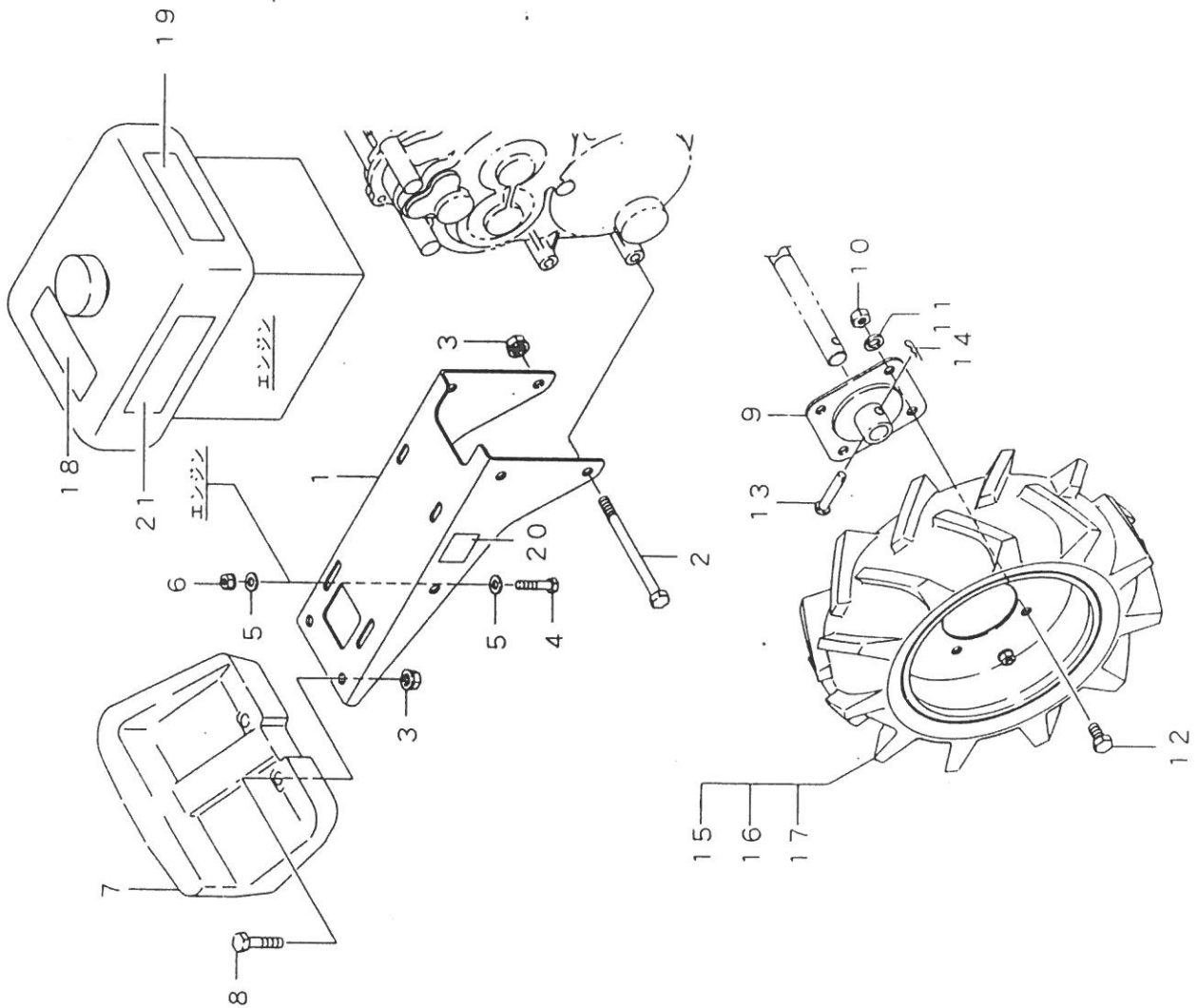

FIG. 5 Engine Base & Tire

Ref.	Parts No.	Parts Name	Qty	Ex-works	Remarks
1	80-1260-301-00	Engine Base	1	¥1,434	
2	89-1113-101352	Hexagonal Bolt(8T) M10*135	2	¥249	
3	89-1541-100002	Hexagonal Nut(SW) M10	4	¥13	
4	89-1113-080402	Hexagonal Bolt(8T) M8*40	4	¥25	
5	89-1713-080002	Washer 8	6	¥5	
6	89-1541-080002	Hexagonal Nut(SW) M8	4	¥11	
7	80-1260-343-00	Balance Weight	1	¥2,235	
8	89-1113-100452	Hexagonal Bolt(8T) M10*45	2	¥42	
9	80-1260-413-00	Wheel Boss	2	¥1,051	
10	89-1511-100042	Hexagonal Nut M10	8	¥7	
11	89-1750-100002	Spring Washer 10	8	¥5	
12	89-1111-100202	Hexagonal Bolt M10*20	8	¥16	
13	89-2181-090452	Flat-Headed Pin 9*45	2	¥24	
14	89-2131-100002	Snap Pin 10	2	¥8	
15~17	80-1260-411-00	Tire ASSY(3.50*7)	2	¥3,573	
15	80-1260-401-00	Tire(3.50*7)	2	¥1,493	
16	80-1260-404-00	Tube	2	¥480	
17	80-1260-407-00	Wheel	2	¥1,733	
18	83-1515-907-00	Label C, Danger	1	¥59	
19	83-1515-909-00	Label D, Danger	1	¥62	
20		Label, Serial No.	1		
21	80-1260-904-00	Label, Model	1	¥317	

FIG. 6 BELT COVER

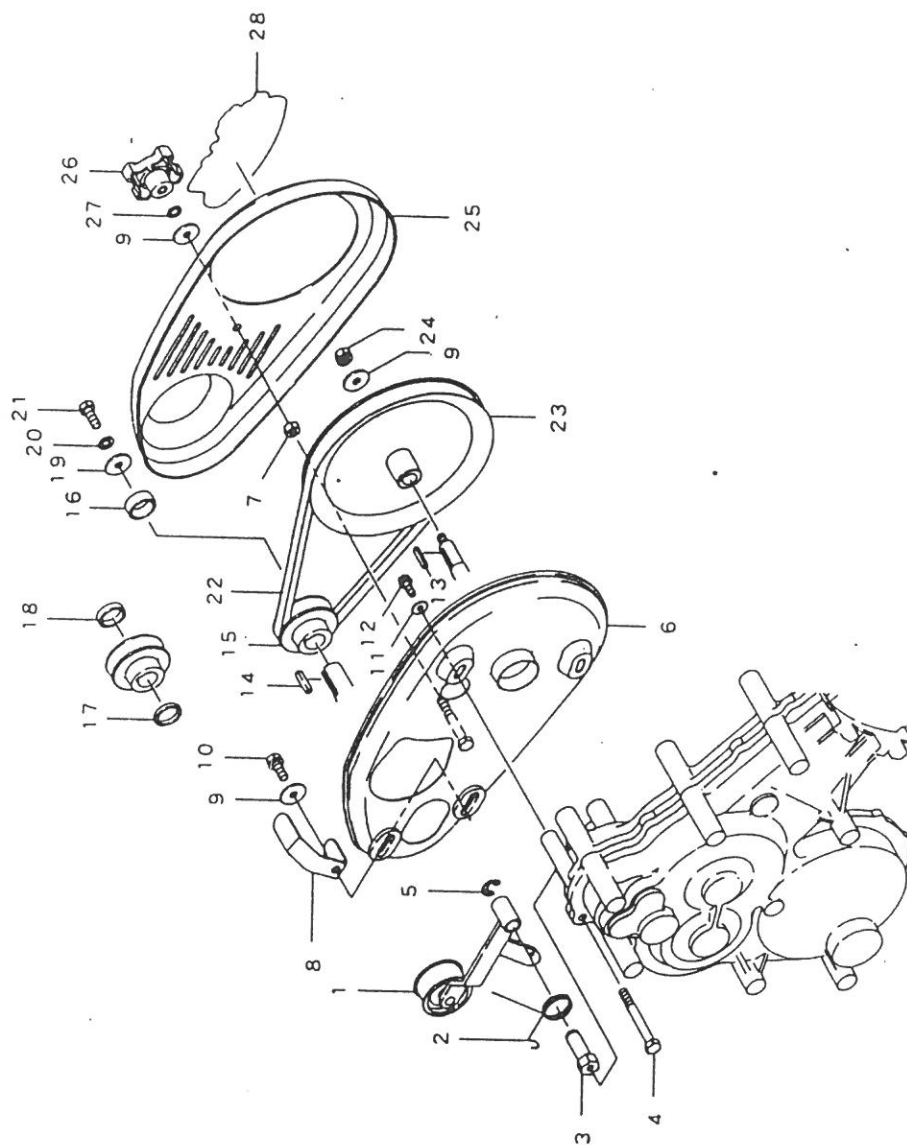

FIG. 6 Belt Cover

Ref.	Parts No.	Parts Name	Qty	Ex-works	Remarks
1	80-1260-542-00	Tension Pulley	1	¥1,860	
2	80-1260-552-00	Spring	1	¥181	
3	80-1260-535-00	Tension Shaft	1	¥157	
4	89-1113-080702	Hexagonal Bolt(8T) M8*70	1	¥51	
5	89-2521-000100	E-Type Stopper 10	1	¥8	
6	80-1260-501-00	Belt Cover In	1	¥1,625	M(Mistubishi)
	80-1260-503-00	Belt Cover In	1	¥1,238	K(Kawasaki)
7	89-1551-080002	U Nut M8	1	¥33	
8	80-1260-575-10	Belt Holder	1	¥249	
9	89-1713-080002	Washer 8	4	¥5	
10	89-1132-080202	Hexagonal Bolt(SW) M8*20	2	¥14	
11	89-1713-060002	Washer 6	2	¥3	
12	83-1020-148-00	Hexagonal Tap Tight M6*14	2	¥11	
13	89-2150-050250	Key 5*25	1	¥35	
14	Engine Parts	Key	1		
15	80-1260-514-00	Engine Pulley	1	¥821	M,K
	80-1260-515-00	Engine Pulley	1	¥821	C
16	80-1260-517-00	Pulley Collar 10L	1	¥85	M,C
17	80-1320-516-00	Pulley Collar In 4L	1	¥40	K
18	80-1320-517-00	Pulley Collar Out 6L	1	¥40	K
19	83-1020-312-00	Washer 8*32*3.2	1	¥79	
20	89-1750-080002	Spring Washer 8	1	¥5	
21	89-1113-080202	Hexagonal Bolt(8T) M8*20	1	¥13	
22	89-6122-003202	V Belt SA32W400-P	1	¥1,188	
23	80-1260-521-00	Transmission Pulley	1	¥1,446	
24	89-1541-080002	Hexagonal Nut(SW) M8	1	¥11	
25	80-1260-502-00	Belt Case Out	1	¥986	
26	80-1020-228-10	Knob Nut M8	1	¥147	
27	89-1812-080002	Toothed Washer 12	1	¥4	
28	80-1260-906-00	Label 2, PICO	1	¥453	

FIG. 7 ROTARY COVER

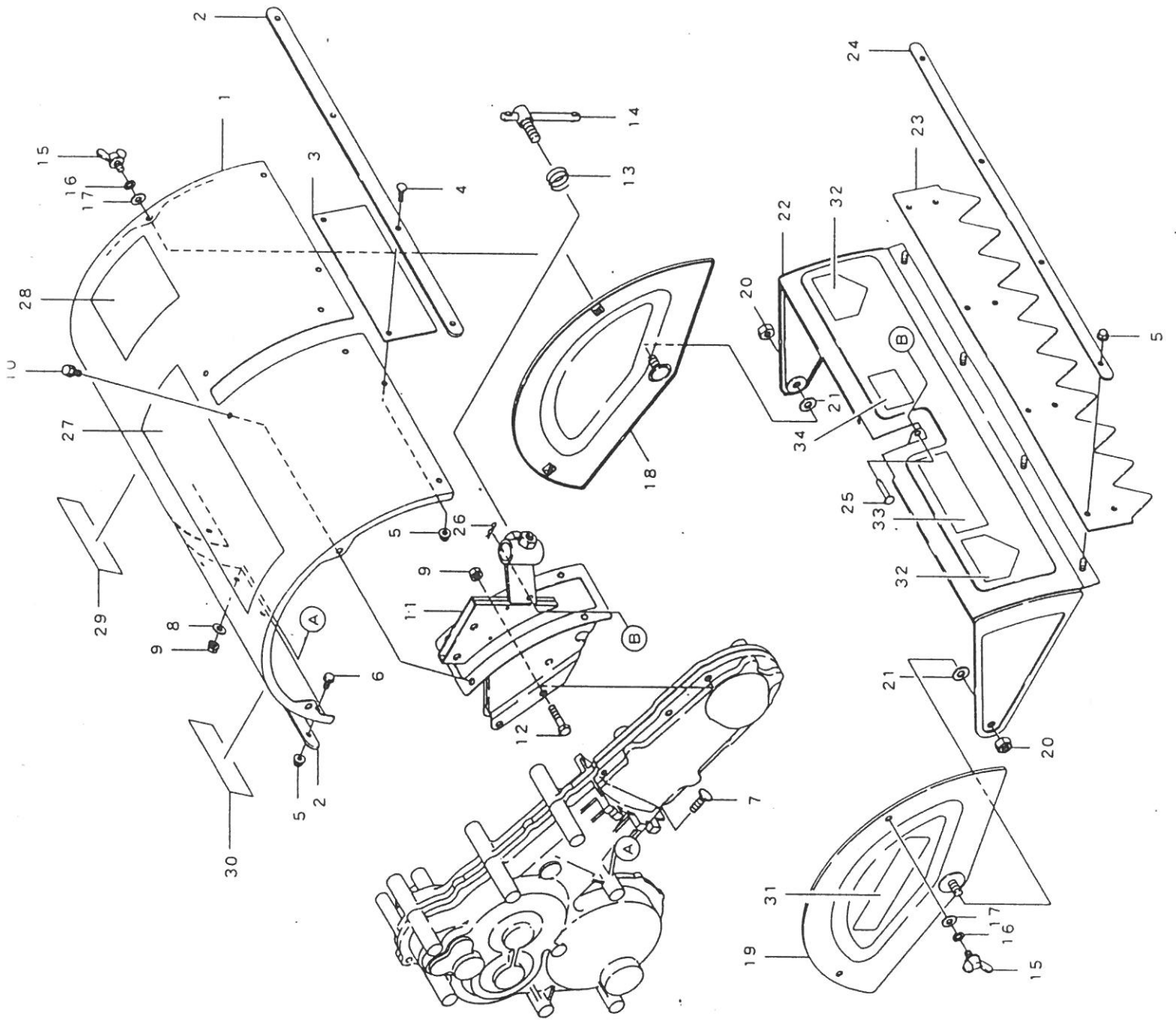

FIG. 7 Rotary Cover

Ref.	Parts No.	Parts Name	Qty	Ex-works	Remarks
1	80-1260-731-00	Rotary Cover	1	¥2,452	
2	80-1260-736-00	Rotary Cover Reinforcement	2	¥258	
3	80-1260-782-00	Rear Flapper B	1	¥48	
4	80-1390-060152	Bolt M6*15	4	¥7	
5	83-1575-189-00	Bagged Nut M6	12	¥8	
6	89-1137-060152	Hexagonal Bolt(PW) M6*15	4	¥5	
7	80-1390-080252	Bolt M8*25	4	¥17	
8	89-1713-080002	Washer 8	4	¥5	
9	89-1541-080002	Hexagonal Nut(SW) M8	6	¥11	
10	89-1132-080122	Hexagonal Bolt(SW) M8*12	4	¥11	
11	80-1260-741-10	Case	1	¥2,825	
12	89-1113-080352	Hexagonal Bolt(8T) M8*35	2	¥24	
13	80-1020-263-00	Lever Shaft Spring	1	¥40	
14	83-1210-487-00	Handle M12*48	1	¥440	
15	89-1311-080152	Butterfly Bolt M8x15	4	¥161	
16	89-1750-080002	Spring Washer 8	4	¥5	
17	89-1711-080002	Washer 8	4	¥5	
18	80-1260-761-00	Side Cover (L)	1	¥1,563	
19	80-1260-762-00	Side Cover (R)	1	¥1,563	
20	89-1551-100002	U Nut M10	2	¥32	
21	89-1713-100002	Washer 10	2	¥7	
22	80-1260-734-00	Rotary	1	¥2,080	
23	80-1260-781-00	Rear Flapper A	1	¥156	
24	80-1260-786-00	Flapper Holder	1	¥214	
25	89-2181-060302	Flat-Headed Pin 6*30	1	¥35	
26	89-2131-080002	Snap Pin 8	1	¥6	
27	80-1260-905-00	Label 1, PICO	1	¥520	
28	80-1260-926-00	Label, Instruction	1	¥173	
29	83-1018-914-00	Label G, Danger	1	¥62	
30	83-1515-911-00	Label B, Danger	1	¥59	
31	80-1260-903-00	Label, Company Name	2	¥88	
32	83-1260-906-10	Label 1, Danger	2	¥68	
33	83-1260-916-00	Label H, Danger	1	¥62	
34	83-1516-908-00	Label 17, Caution	1	¥24	

FIG. 8 ROTARY & RESISTANCE ROD

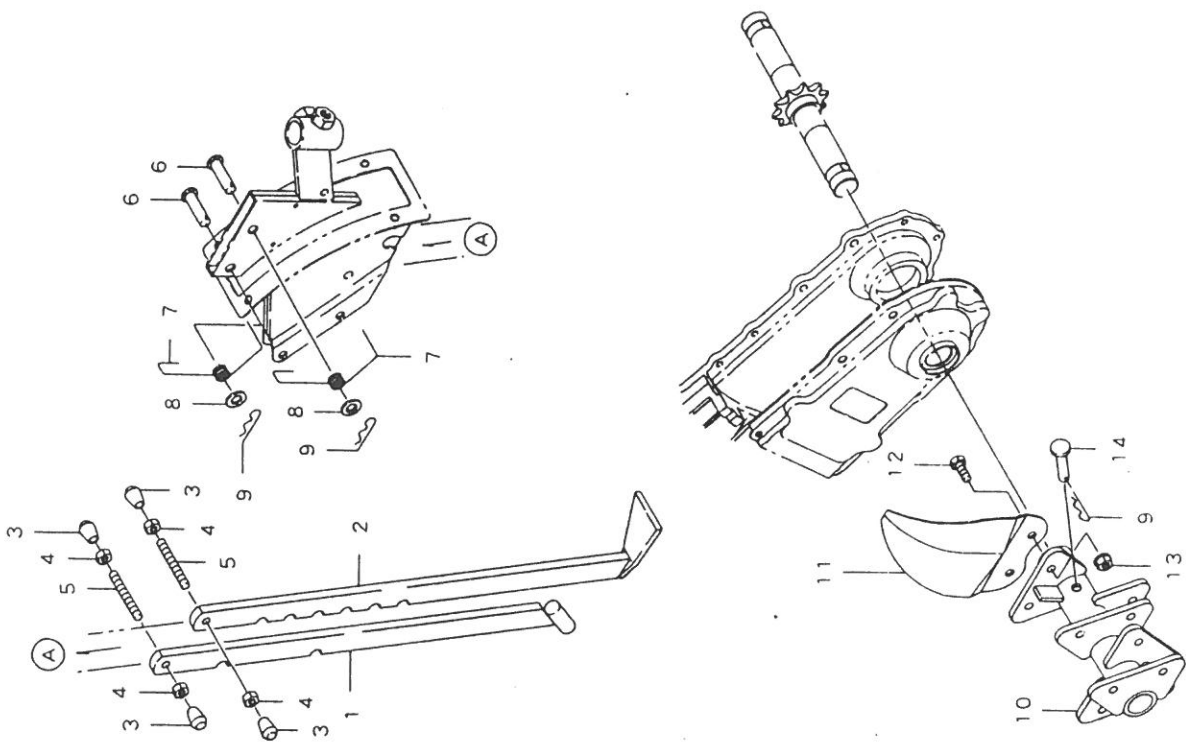

FIG. 8 Rotary & Resistant Bar

Ref.	Parts No.	Parts Name	Qty	Ex-works	Remarks
1	80-1260-744-00	Resistant Bar	1	¥933	
2	80-1260-743-00	Bar for Tilling Depth Adjustment	1	¥543	
3	83-1260-423-00	Grip Rubber	4	¥53	
4	89-1511-080042	Hexagonal Nut M8	4	¥7	
5	80-1260-745-00	Screw M8*58	2	¥27	
6	89-2181-100352	Flat-Headed Pin 10*35	2	¥35	
7	80-1260-746-00	Spring	2	¥155	
8	89-1713-100002	Washer 10	2	¥7	
9	89-2131-100002	Snap Pin 10	4	¥8	
10	80-1260-803-00	Tine Shaft	2	¥2,567	
11	80-1260-821-00	Tine for SF50	12	¥267	
12	89-1113-080202	Hexagonal Bolt(8T) M8*20	24	¥13	
13	89-1541-080002	Hexagonal Nut(SW) M8	24	¥11	
14	89-2181-090452	Flat-Headed Pin 9*45	2	¥24	