

Parts catalogue

Transporter

(EXPORT MODEL)

LS280

MODEL
LS280

CODE
0914-00000

CONTENTS

Fig. 1 TRANSMISSION	1
Fig. 2 ENGINE	6
Fig. 3 FRAME	8
Fig. 4 HANDLE	10
Fig. 5 CRAWLER	12
Fig. 6 PLATFORM	14

OREC CO.,LTD

Update : Mar. 2018

MEMO

- *1) Interchangeable
- *2) Serial Number : LS280 : ~UA05K00005
- *3) Serial Number : LS280 : UA05K00006~
- *4) Serial Number : LS280 : ~UA06J00100
- *5) Serial Number : LS280 : UA07A00001~
- *6) Serial Number : LS280 : ~UA07G00042
- *7) Serial Number : LS280 : UA07G00043~
- *8) Serial Number : LS280 : ~UA08B00029
- *9) Serial Number : LS280 : UA08G00030~
- *10) Serial Number : LS280 : UA17M00001~

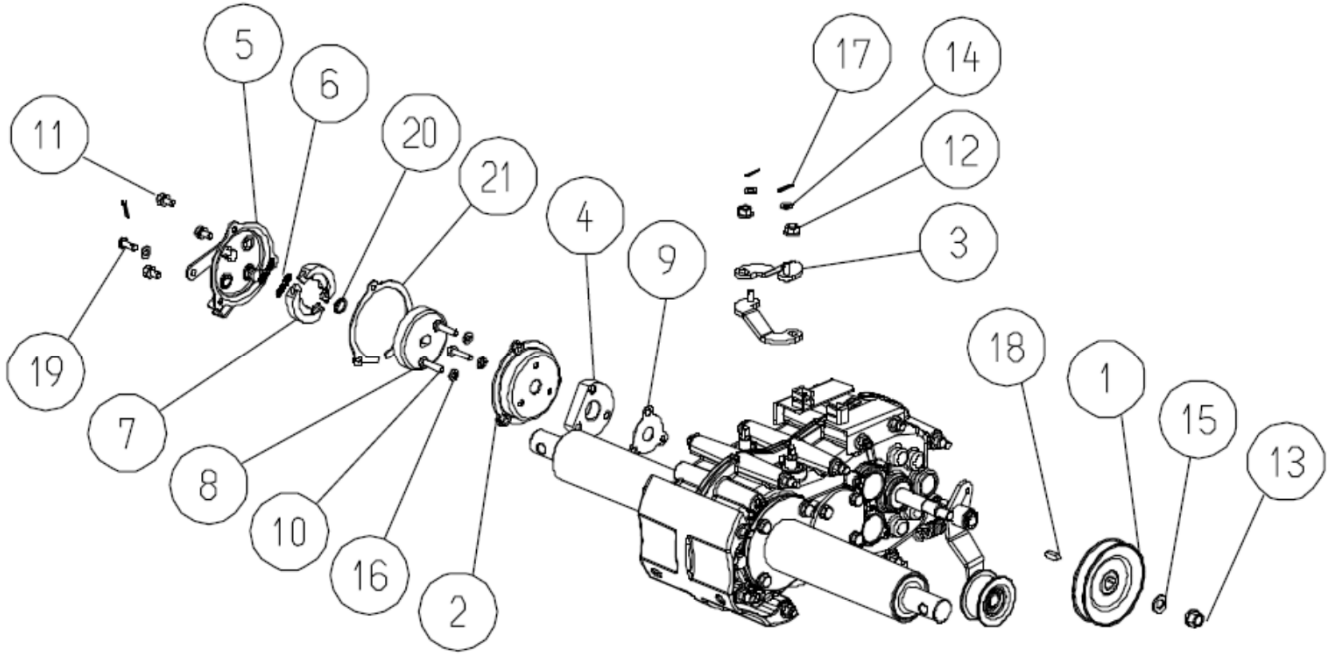

Ref.	Parts Number	Parts Name	Quantity	Remarks
1	80-1516-521-00	Transmission Pulley	1	#1
2	80-1614-312-00	Brake Cover CMP	1	
3	80-1920-153-00	Side Clutch Arm	2	
4	80-1920-313-00	Brake Cover Spacer	1	
5	85-1445-311-00	Brake	1	
5-8	0914-73000	Brake ASSY(W6308)	1	
6	85-1711-317-00	Shoe Return Spring	2	
7	85-1711-316-00	Brake Shoe	1	
8	85-1445-313-00	Brake Drum	1	
9	85-1445-317-00	Brake Packing(Small)	1	
10	89-1111-060252	Hexagonal Bolt M6*25	3	
11	89-1132-060122	Hexagonal Bolt (SW) M6*12	3	
12	89-1543-080002	Mini Hexagonal Nut (SW) M8	2	
13	89-1543-100002	Mini Hexagonal Nut(SW) M10	1	# 1
14	89-1711-060002	Flat Washer 6	3	
15	89-1711-100002	Flat Washer 10	1	# 1
16	89-1750-060002	Spring Washer 6	3	
17	89-2120-200152	Split Pin 2*15	3	
18	89-2150-050180	Key 5*18(Round)	1	#1
19	89-2181-060162	Flat Head Pin 6*16	1	
20	89-2511-000130	Snap Ring (S13)	1	
21	0211-31800	Brake Packing(Large)	1	
	0914-01000	Transmission ASSY	1	Excluding items marked #1

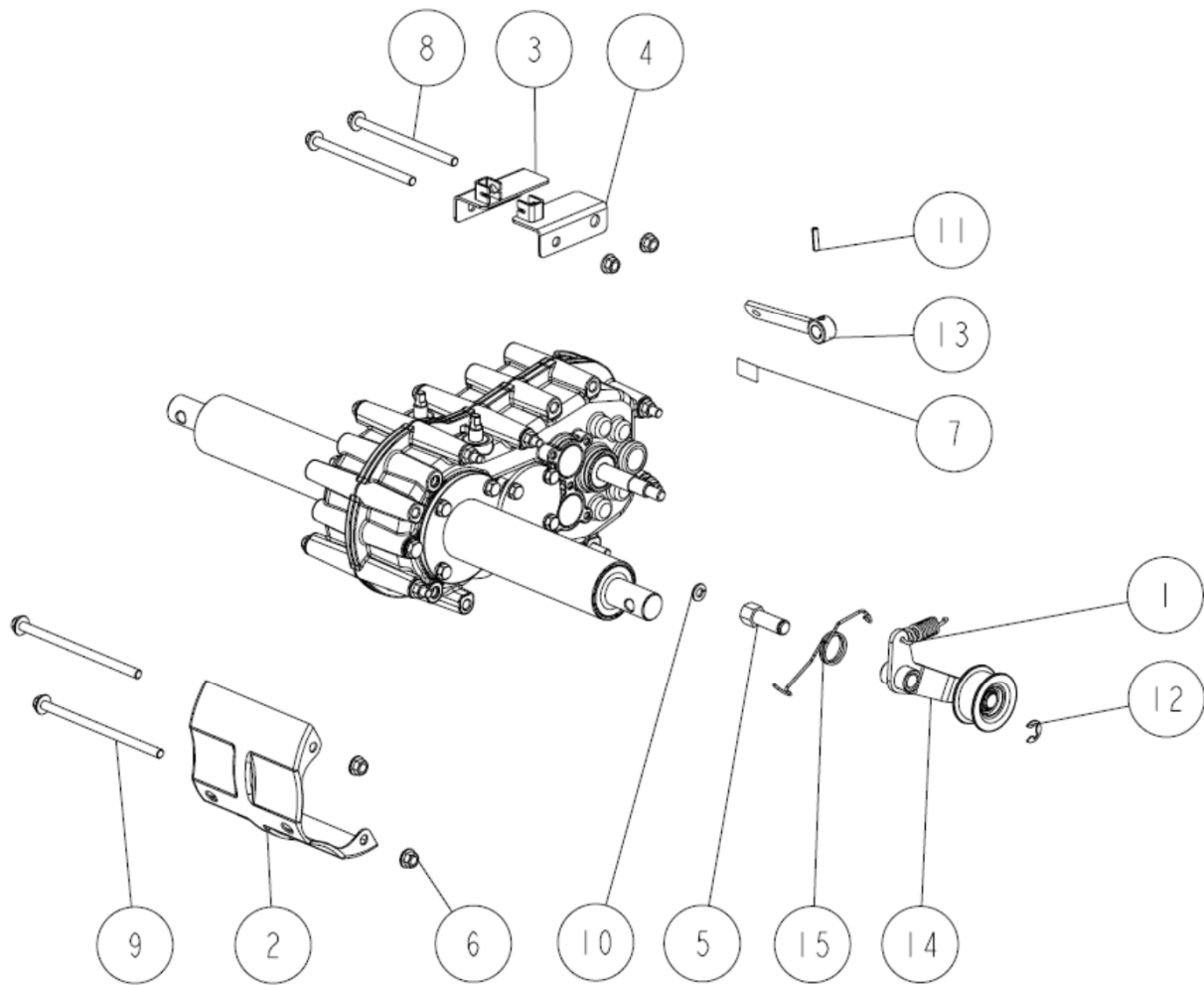

Ref.	Parts Number	Parts Name	Quantity	Remarks
1	80-1425-551-00	Differential Lock Spring	1	#1
2	80-1920-117-00	Transmission Guard	1	
3	80-1920-197-00	Side Clutch Wire Receiver (L)	1	
4	80-1920-198-00	Side Clutch Wire Receiver (Right)	1	
5	80-1920-535-00	Driving Tension Arm Setting Shaft	1	#1
6	83-1484-255-00	Lock Nut ZUF M8	11	
7	83-1712-923-00	Label, Oil Quantity 1.6 L	1	
8	89-1251-081203	Flange Hexagonal Bolt M8*120	6	
9	89-1251-081453	Flange Hexagonal Bolt M8*145	6	
10	89-1750-080002	Spring Washer 8	1	#1
11	89-2111-050020	Spring Pin 5*20	1	
12	89-2521-000100	E Type Ring 10	1	#1
13	0914-01300	Change Arm	1	
14	0914-50300	Driving Tension Arm	1	*8) #1
	0914-50310	Driving Tension Arm	1	*9) #1
15	0914-55200	Driving Tension Arm Return Spring	1	*8) #1
	0223-71100	Driving Tension Arm Return Spring	1	*9) #1

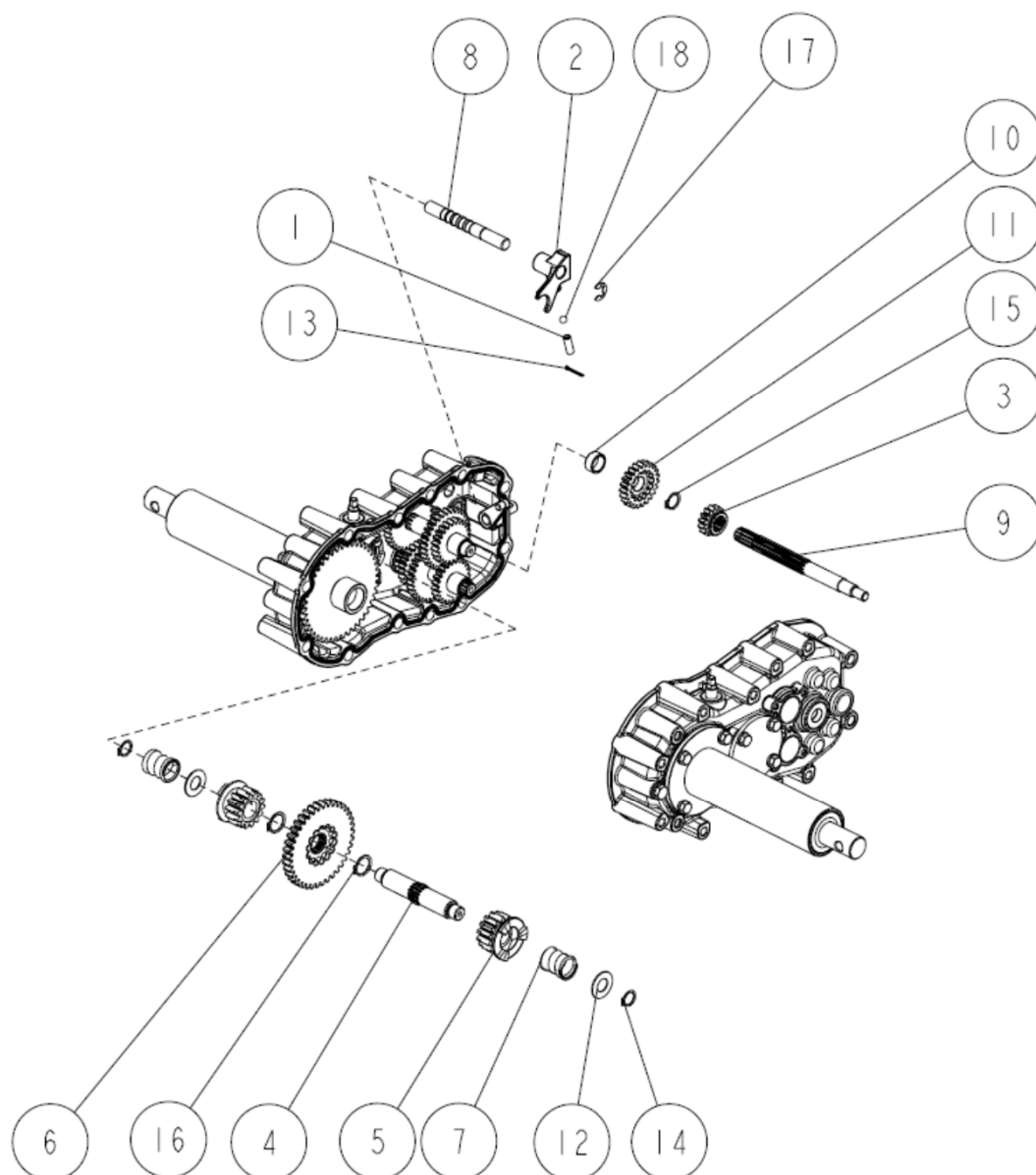

Ref.	Parts Number	Parts Name	Quantity	Remarks
1	80-1310-138-00	Spring 1.4	1	
2	80-1575-108-10	1st Shaft Shift Folk	1	
3	80-1575-120-10	1st Shaft Shift Gear 14T	1	*4)
	0913-01200	1st Shaft Shift Gear 14T	1	*1) *5)
4	80-1575-140-00	Side Clutch Shaft	1	
5	80-1575-141-00	Side Clutch Gear 14T	2	
6	80-1575-142-00	Side Clutch Gear 38T	1	
7	80-1575-162-00	Side Clutch Spring	2	
8	80-1920-107-00	Shift Fork Shaft	1	
9	80-1920-118-10	Main Shaft	1	
10	80-1920-119-00	Collar D	1	
11	80-1920-121-00	Top Gear 23T	1	
12	83-1633-362-10	Thrust Washer 15*30*1.2	2	
13	89-2120-200202	Split Pin 2*20	1	
14	89-2511-000150	Snap Ring (S15)	2	
15	89-2511-000160	Snap Ring (S16)	1	
16	89-2511-000200	Snap Ring (S20)	2	
17	89-2521-000100	E Type Ring 10	1	
18	89-3410-075000	Steel Ball 7.5	1	

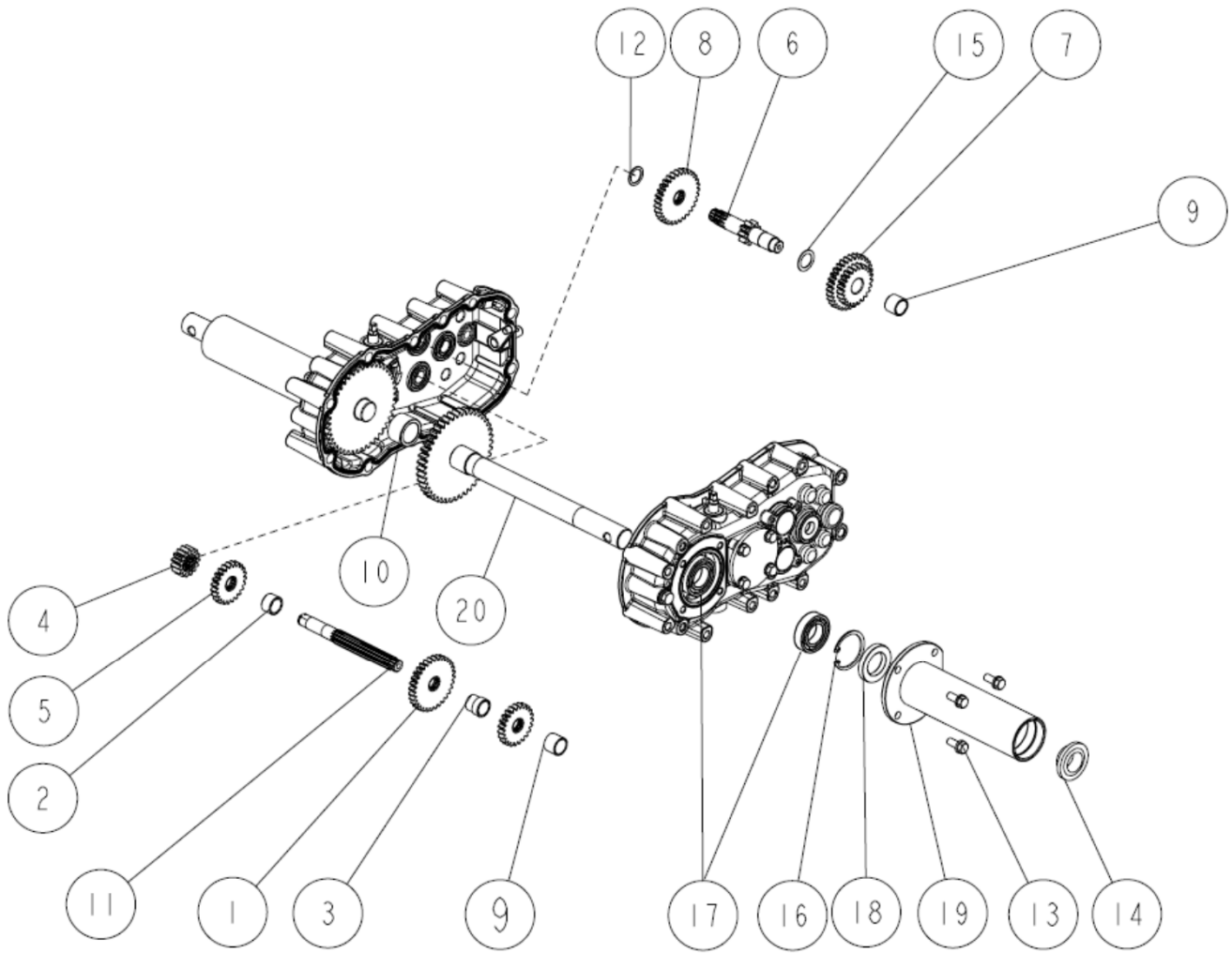

Ref.	Parts Number	Parts Name	Quantity	Remarks
1	80-1920-128-00	2 Shaft Gear 32T	1	*4)
	0913-01300	2 Shaft Gear 32T	1	*1) *5)
2	80-1920-130-00	Collar A	1	
3	80-1920-131-00	Collar B	1	
4	80-1920-132-00	2 Shaft Gear 15T	1	
5	80-1920-133-00	2 Shaft Gear 23T	2	
6	80-1923-138-00	3 Shaft	1	
7	80-1920-139-00	Back Gear CMP	1	*4)
	0913-01400	Back Gear CMP	1	*1) *5)
8	80-1920-140-00	3 Shaft Gear 31T	1	
9	80-1920-141-00	Collar C	2	
10	80-1920-147-00	Axle Collar	1	
11	80-1923-127-00	2 Shaft	1	
12	83-1017-365-10	Thrust Washer 17*23*1.0	1	
13	83-1415-127-00	Seal Bolt (SW) M8*20	8	
14	83-1415-663-00	Oil Seal AP 30.47.7	2	
15	83-1830-368-00	Thrust Washer 18*26*1.0	1	
16	89-2512-000470	Snap Ring (R47)	2	
17	89-3111-060054	Bearing 6005	4	
18	89-5121-304707	Oil Seal UE 30.47.7	2	
19	0914-01100	Axle BB Case	2	
20	0914-01200	Axle	2	

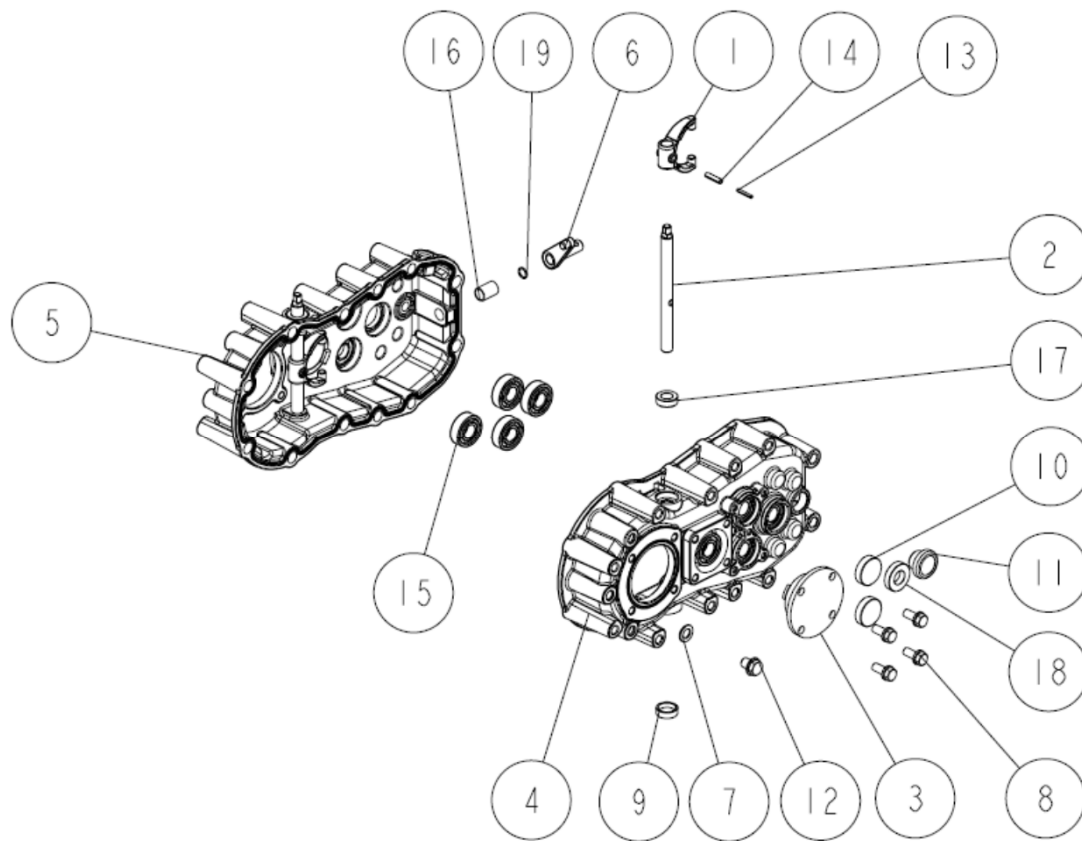

Ref.	Parts Number	Parts Name	Quantity	Remarks
1	80-1415-114-00	Side Clutch Folk	2	
2	80-1425-112-00	Differential Lock Fork Shaft	2	
3	80-1575-152-10	Side Clutch Shaft BB Case	2	
4	80-1920-101-00	Transmission Case (L)	1	
5	80-1920-103-00	Transmission Case (R)	1	
6	80-1920-106-00	Swing Arm	1	
7	83-1020-349-00	Copper Packing 10.5*18*1.6	1	
8	89-1238-080162	Mini Hexagonal Bolt (SW) M8*16	8	
9	83-1415-671-00	Blind Cover 22	2	
10	83-1415-672-00	Blind Cover 30	4	
11	83-1517-685-00	Oil Cap 20	2	
12	89-1252-100123	Flange Mini Hexagonal Bolt(slender) M10*12	1	
13	89-2111-030020	Spring Pin 3*20	2	
14	89-2111-050020	Spring Pin 5*20	2	
15	89-3111-062024	Bearing 6202	8	
16	89-3510-012200	DU Bush 12.20	1	
17	89-5121-122207	Oil Seal UE 12.22.7	2	
18	89-5121-153007	Oil Seal UE 15.30.7	2	
19	89-5221-009000	O Ring P9	1	

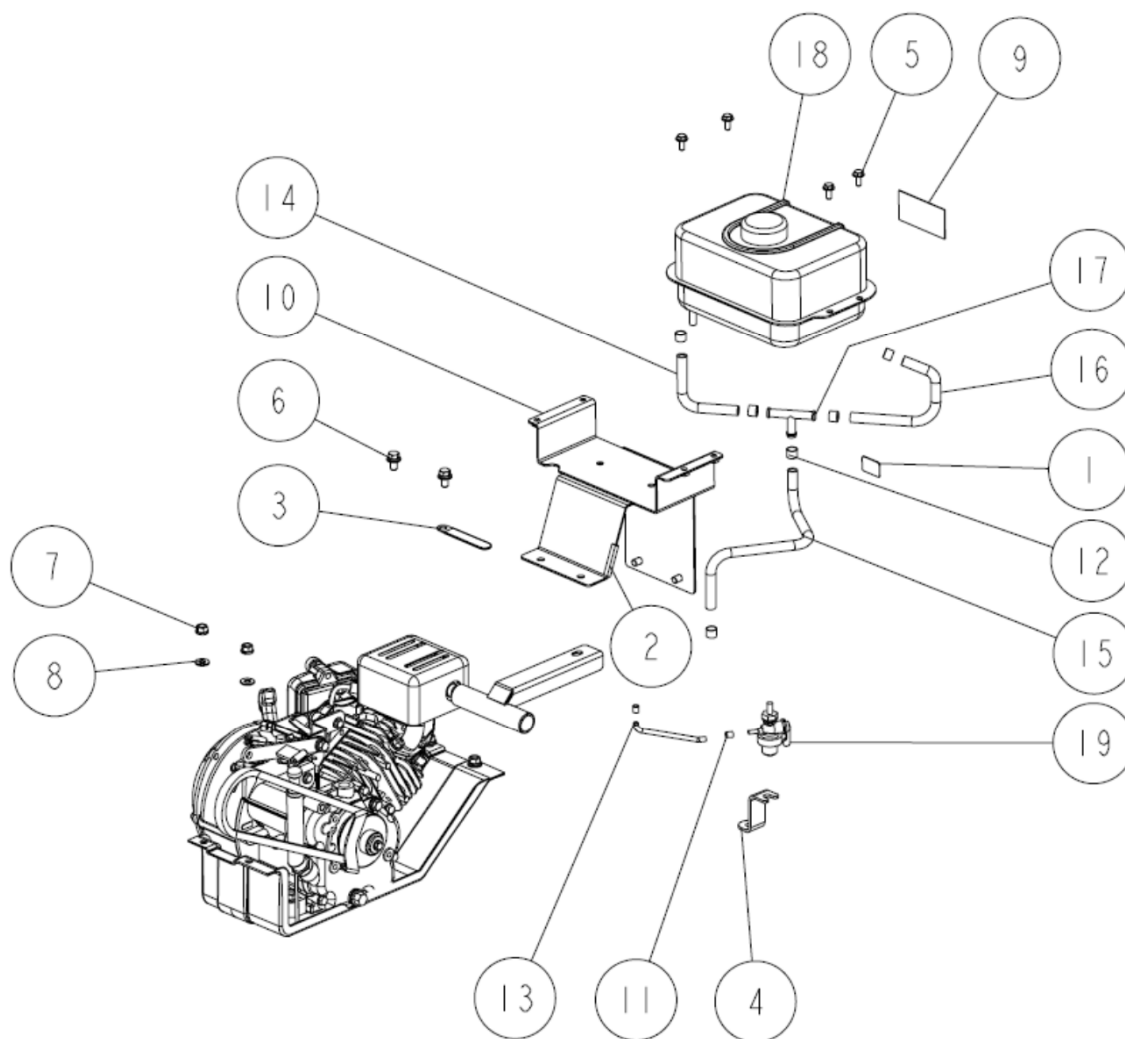

Ref.	Parts Number	Parts Name	Quantity	Remarks
1	80-1010-933-00	Label, CE	1	
2	80-1482-492-00	Rubber L40	1	
3	80-1792-988-00	Harness Clip 8	1	
4	80-1920-304-00	Fuel Cock Attachment	1	
5	89-1137-060152	Hexagonal Bolt(PW) M6*15	4	
6	89-1233-080162	Mini Hexagonal Bolt (PWSW) M8*16	4	
7	89-1543-080002	Mini Hexagonal Nut (SW) M8	4	
8	89-1711-080002	Flat Washer 8	4	
9	0214-72100	Label, Caution for Engine etc	1	
10	0914-50400	Fuel Tank Attachment	1	
11	88-92037-2116	Hose Clip	2	
12	88-92170-2082	Hose Clip	6	
13	Engine Parts	Fuel Hose (A)	1	
14	Engine Parts	Fuel Hose (B)	1	
15	Engine Parts	Fuel Hose (C)	1	
16	Engine Parts	Fuel Hose (D)	1	
17	88-92005-1143	Fuel Hose Joint	1	
18	Engine Parts	Fuel Tank CMP	1	
19	88-51023-2131	Fuel Cock Assy	1	

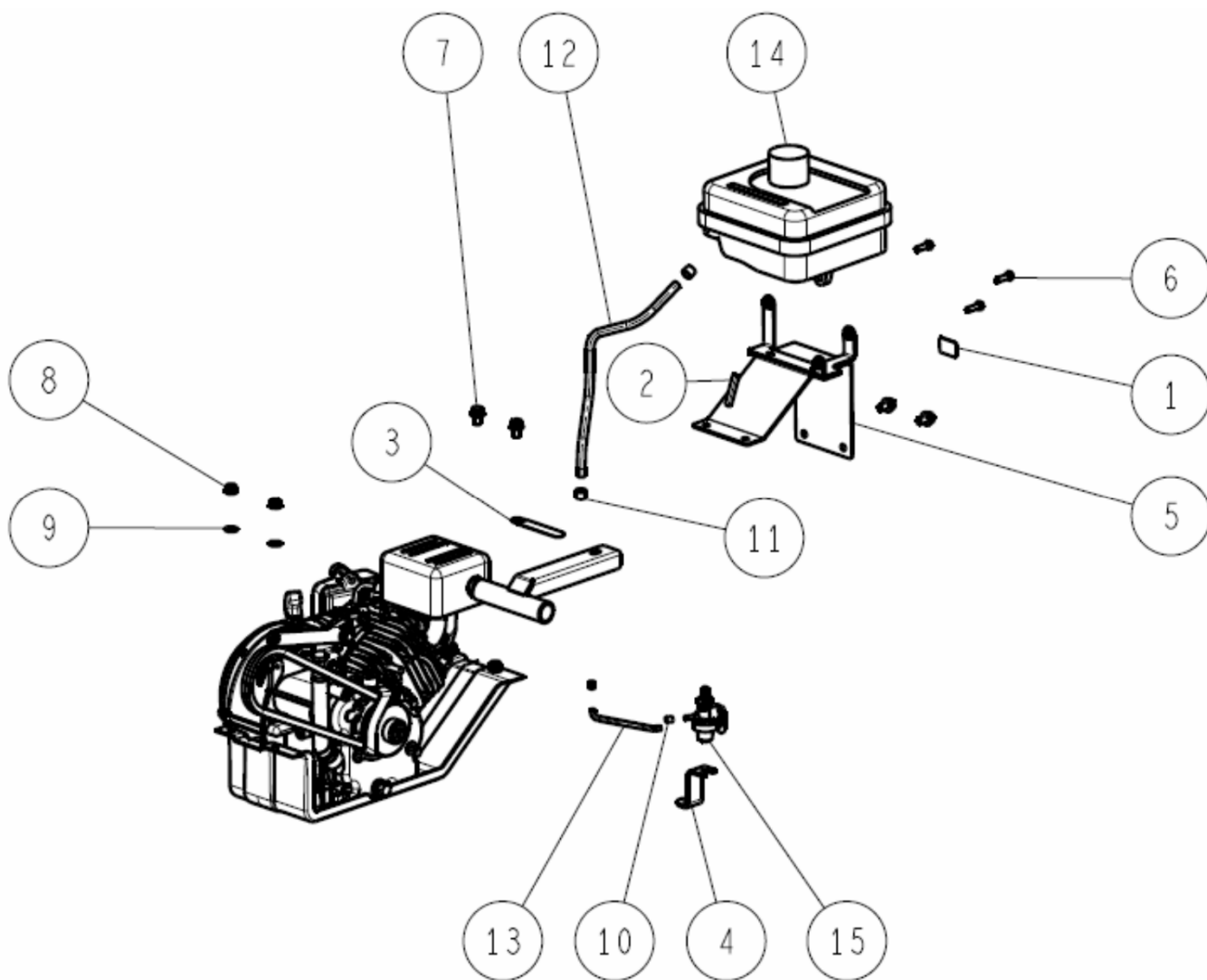

Ref.	Parts Number	Parts Name	Quantity	Remarks
1	80-1010-933-00	Label, CE	1	
2	80-1482-492-00	Rubber L40	1	
3	80-1792-988-00	Harness Clip 8	1	
4	80-1920-304-00	Fuel Cock Attachment	1	
5	0914-50500	Fuel Tank Attachment	1	
6	89-1113-060202	Hexagonal Bolt (8T) M6*20	3	
7	89-1233-080162	Mini Hexagonal Bolt (PWSW) M8*16	4	
8	89-1543-080002	Mini Hexagonal Nut (SW) M8	4	
9	89-1711-080002	Flat Washer 8	4	
10	88-92173-2004	CLAMP	2	
11	88-92173-2003	CLAMP	2	
12	88-92192-1912	TUBE 6x10x330	1	
13	88-92192-1635	TUBE 4x8x300	1	
14	Engine Parts	Fuel Tank CMP	1	
15	88-51023-2176	TAP-ASSY	1	

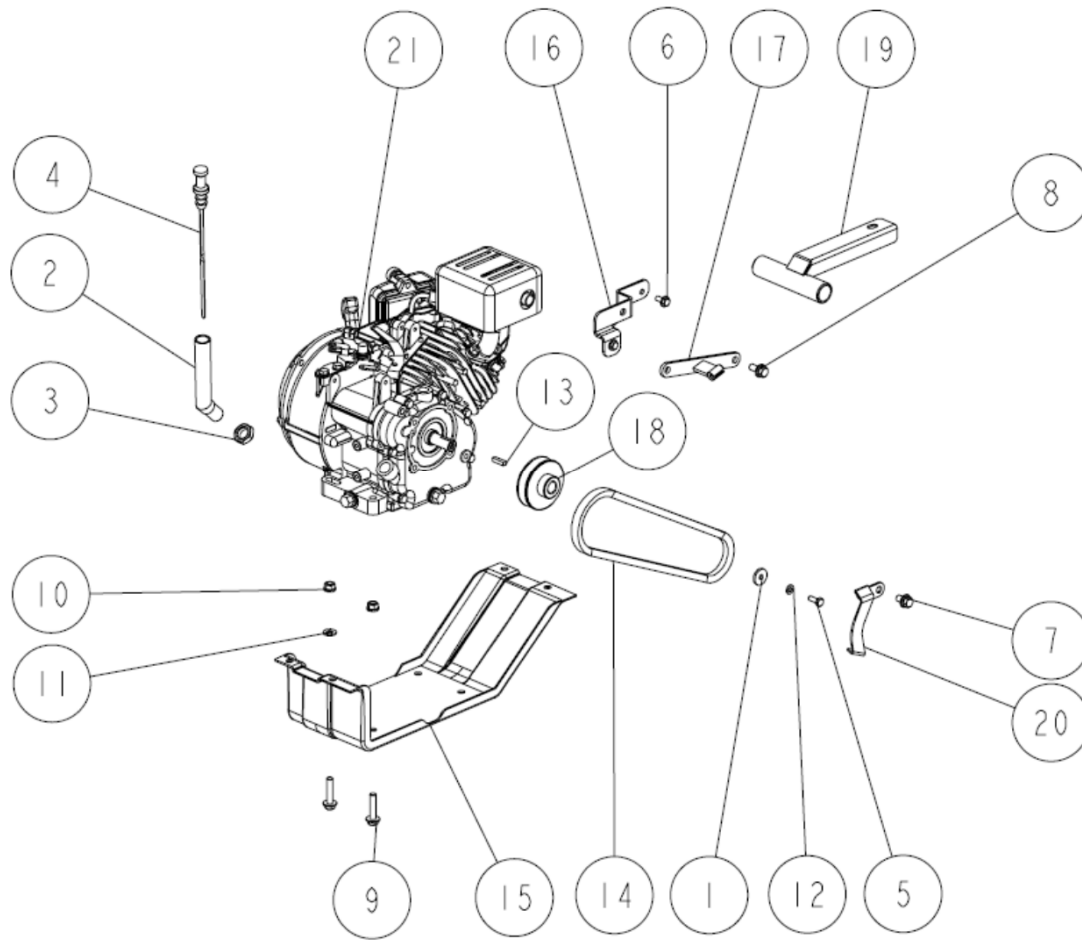

Ref.	Parts Number	Parts Name	Quantity	Remarks
1	83-1482-311-00	Washer 6.5*22*3.2	1	
2	0026-20100	Tube Oil Gauge	1	
3	0026-20200	Nut M18 P=2.5	1	
4	0026-70700	Oil Gauge	1	
5	89-1113-060162	Hexagonal Bolt (8T) M6*16	1	
6	89-1137-060152	Hexagonal Bolt(PW) M6*15	2	
7	89-1233-080162	Mini Hexagonal Bolt (PWSW) M8*16	1	
8	89-1233-080202	Mini Hexagonal Bolt(PWSW) M8*20	1	
9	89-1253-080352	Mini Hexagonal Bolt(8T) M8*35	4	
10	89-1543-080002	Mini Hexagonal Nut (SW) M8	4	
11	89-1711-080002	Flat Washer 8	1	
12	89-1750-060002	Spring Washer 6	1	
13	89-2152-050200	Key 5*20	1	
14	89-6122-002801	V Belt LA28	1	
15	0914-20300	Engine Base	1	
16	0914-50100	Plate Setting Base	1	
17	0914-50200	Plate	1	*8)
	0914-50210	Plate	1	*9)
18	0914-51100	Engine Pulley	1	
19	0914-51200	Exhaust Pipe	1	
20	0914-51300	Engine Pulley Belt Stopper	1	
21		Engine	1	

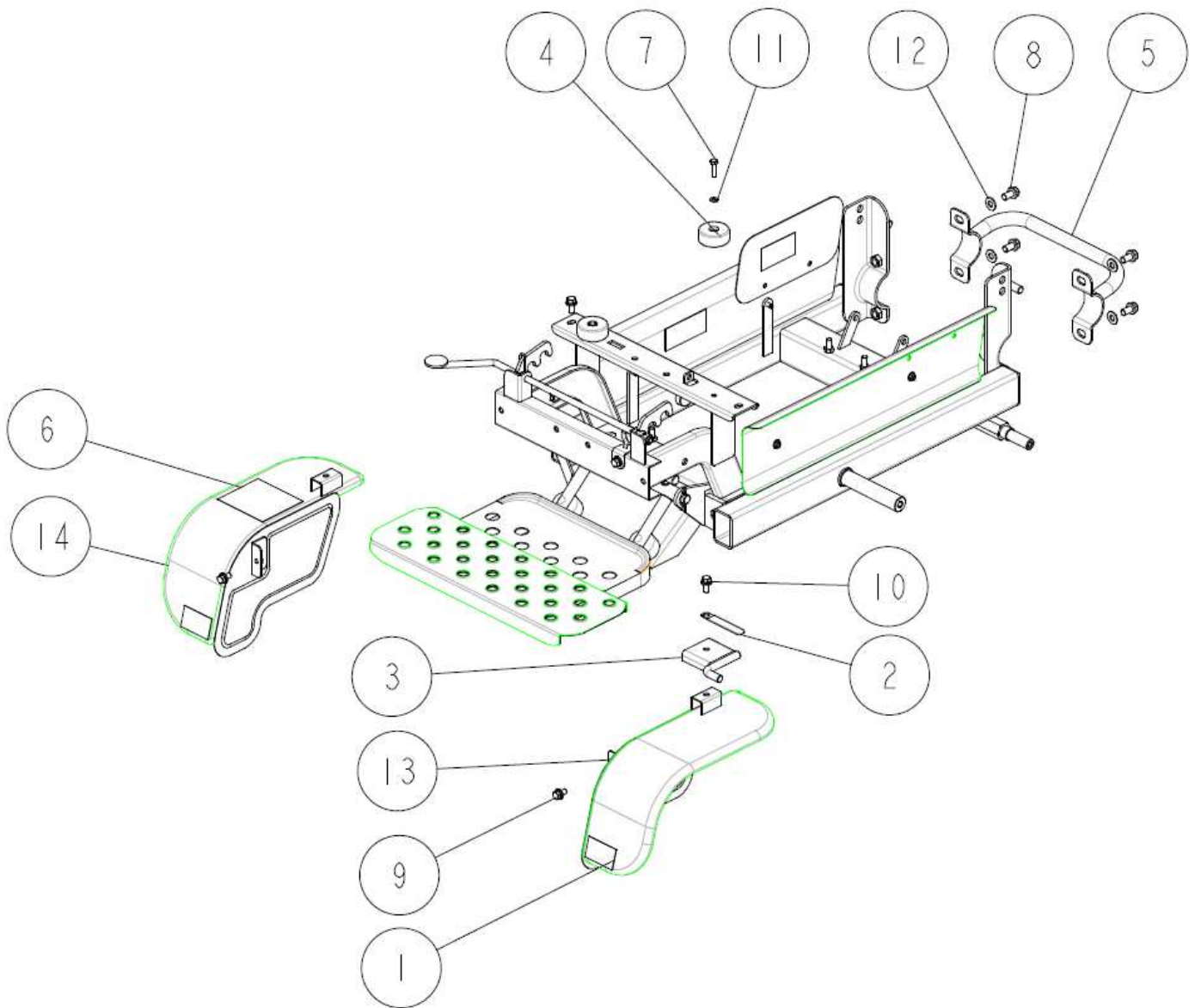

Ref.	Parts Number	Parts Name	Quantity	Remarks
1	80-1484-907-00	Reflection Seat (Yellow)	2	
2	80-1792-988-00	Harness Clip 8	1	
3	80-1920-303-00	Stopper Lock Pin	1	
4	80-1920-306-00	Stopper Rubber B-4	2	
5	80-1920-354-00	Bumper	1	
6	80-1920-A08-00	Label	1	
7	89-1111-060252	Hexagonal Bolt M6*25	2	
8	89-1232-100202	Mini Hexagonal Bolt(SW) M10*20	4	
9	89-1233-080162	Mini Hexagonal Bolt (PWSW) M8*16	2	
10	89-1233-080202	Mini Hexagonal Bolt(PWSW) M8*20	2	
11	89-1711-060002	Flat Washer 6	2	
12	89-1714-100002	Flat Washer 10	4	
13	0914-40100	Fender (Right)	1	
14	0914-40200	Fender (Left)	1	

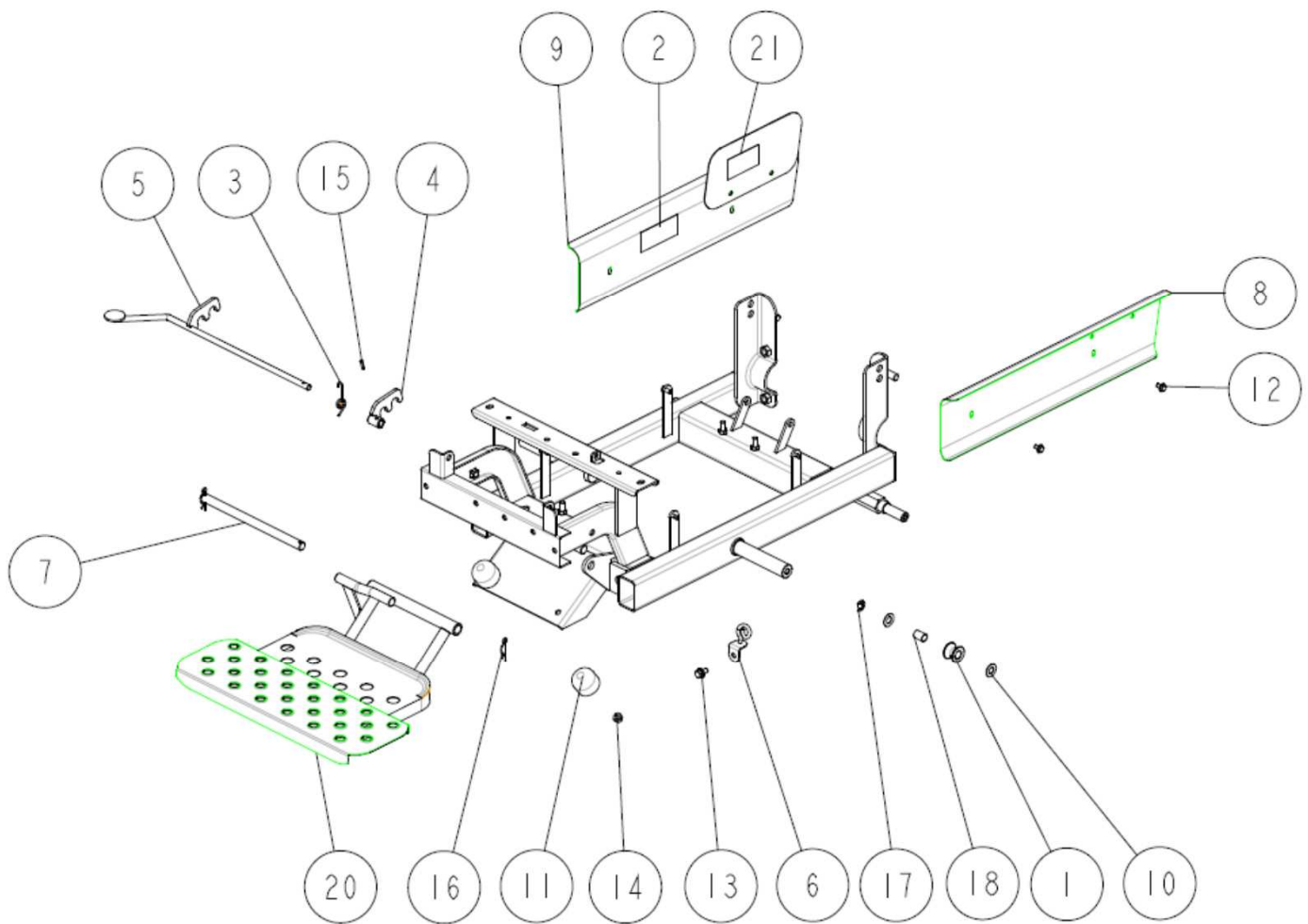

Ref.	Parts Number	Parts Name	Quantity	Remarks
1	80-1484-354-10	Brake Rod Roller	1	
2	80-1488-928-10	Label, Caution for Belt Involving	2	
3	80-1920-215-10	Stopper Return Spring	1	
4	80-1920-216-20	Handle Up/Down Stopper Arm	1	
5	80-1920-217-20	Handle Up/Down Stopper Pedal	1	
6	80-1920-302-00	Recoil Grip Holder	1	
7	80-1920-393-00	Step Setting Shaft	1	
8	80-1920-751-10	Guard (Right)	1	
9	80-1920-752-20	Guard (Left)	1	
10	83-1020-355-00	Thrust Washer 12*24*1.0	2	
11	84-1783-647-00	Stopper Rubber EH-1003	2	
12	89-1137-060122	Hexagonal Bolt (PW) M6*12	4	
13	89-1233-080162	Mini Hexagonal Bolt (PWSW) M8*16	1	
14	89-1543-080002	Mini Hexagonal Nut (SW) M8	2	
15	89-2111-040018	Spring Pin 4*18	1	
16	89-2131-160002	Snap Pin 16	2	
17	89-2521-000100	E Type Ring 10	1	
18	89-3510-012200	DU Bush 12.20	1	
19	0914-20100	Frame	1	
20	0914-21100	Step	1	
21	0914-77200	Label, Belt Size	1	

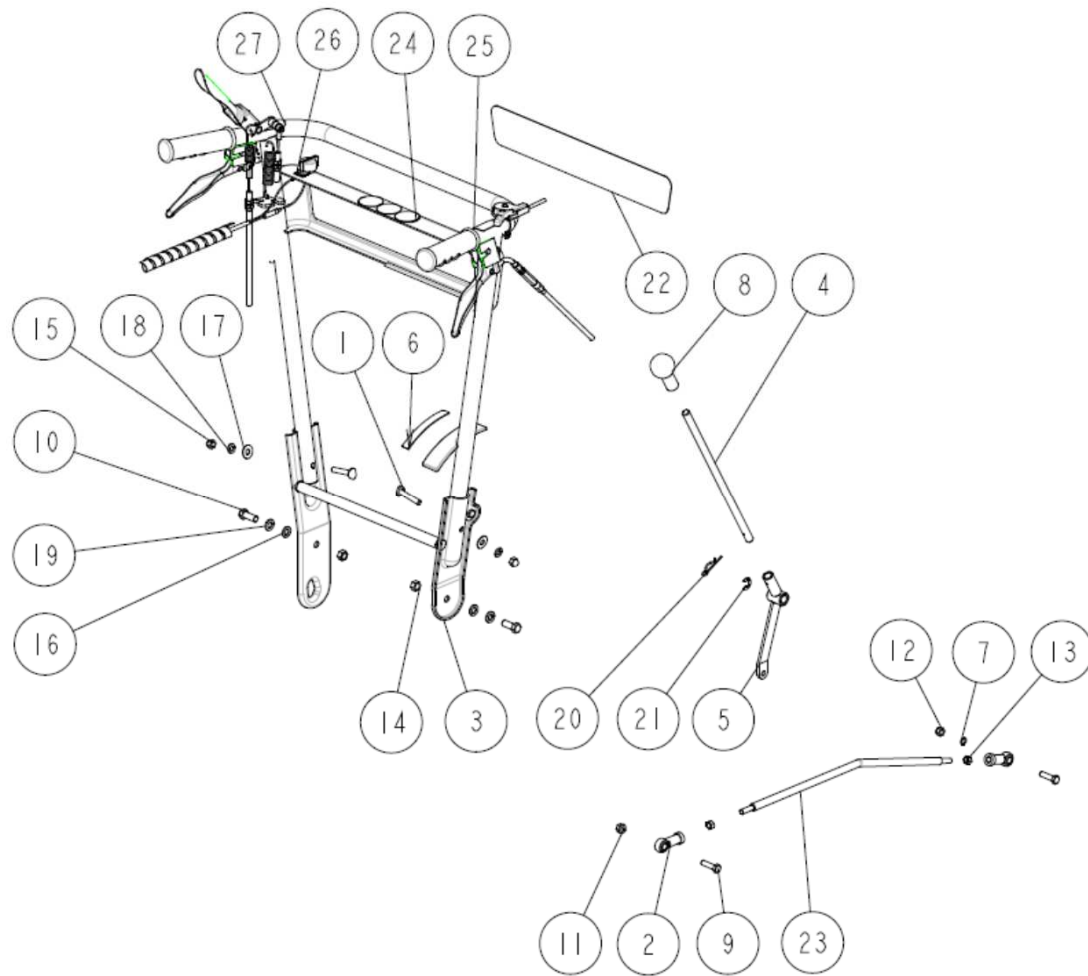

Ref.	Parts Number	Parts Name	Quantity	Remarks
1	80-1021-227-00	Handle Fixing Bolt M8*45	2	
2	80-1487-963-00	Rod End HS8	2	
3	80-1920-201-00	Handle Attachment	1	
4	80-1920-262-00	Change Lever	1	
5	80-1920-263-30	Change Lever Attachment	1	
6	80-1920-911-10	Label, Change	1	
7	83-1920-311-00	Washer 8.1*12*0.5	1	
8	83-1920-731-00	Grip, Rubber 12	1	
9	89-1211-080302	Mini Hexagonal Bolt M8*30	2	
10	89-1213-100252	Mini Hexagonal Bolt(8T) M10*25	2	
11	89-1543-080002	Mini Hexagonal Nut (SW) M8	1	
12	89-1561-080002	Mini Hexagonal U Nut M8	1	
13	89-1611-080042	Mini Hexagonal Nut M8	2	
14	89-1611-100042	Mini Hexagonal Nut M10	2	
15	89-1671-080043	Mini Hexagonal Cap Nut M8	2	
16	89-1711-100002	Flat Washer 10	2	
17	89-1713-080003	Flat Washer 8	2	
18	89-1750-080003	Spring Washer 8	2	
19	89-1750-100002	Spring Washer 10	2	
20	89-2131-160002	Snap Pin 16	1	
21	89-2521-000100	E Type Ring 10	1	
22	0913-73300	Plate	1	
23	0914-11100	Shift Rod	1	
24	0919-71800	Label,Caution	1	
25	0919-73200	Label,Side Clutch R	1	
26	0919-73300	Label,Engine Stop	1	
27	0919-73400	Label,Side Clutch L	1	

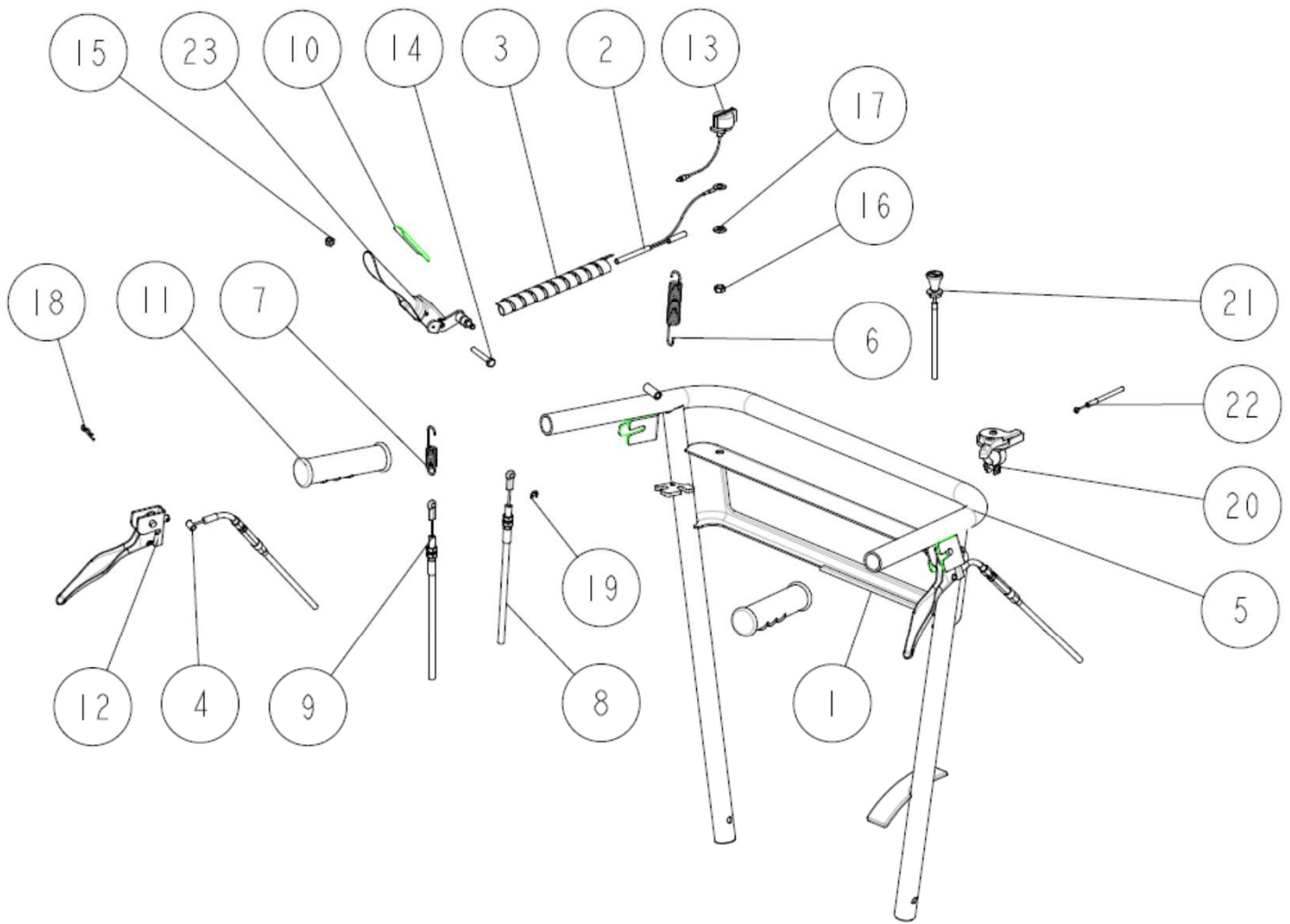

Ref.	Parts Number	Parts Name	Quantity	Remarks
1	80-1020-752-00	Rubber L200	1	
2	80-1260-288-20	Engine Stop Wire Harness	1	
3	80-1920-389-00	Spiral Tube	1	
4	83-1920-962-00	Side Clutch Wire	2	
5	80-1920-A01-00	Handle	1	
6	80-1920-A04-00	Clutch Lever Return Spring	1	
7	80-1920-A05-00	Spring for Brake Return	1	
8	80-1920-A06-00	Driving Clutch Wire	1	
9	80-1920-A07-00	Brake Wire	1	
10	80-1920-A09-00	Label, Driving	1	
11	83-1560-414-00	Handle Grip 27	2	
12	83-1761-457-00	Side Clutch Lever	2	
13	0016-72500	Engine Stop Switch	1	
14	89-1113-060402	Hexagonal Bolt (8T) M6*40	1	
15	89-1553-060002	Bag Hexagonal U Nut M6	1	
16	89-1613-080042	Hexagonal Nut (3 sorts) M8	1	
17	89-1750-080002	Spring Washer 8	1	
18	89-2131-080002	Snap Pin 8	2	
19	89-2521-000050	E Type Ring 5	1	
20	0226-70400	Throttle Lever 27	1	
21	0914-70100	Wire, Choke	1	
22	0914-75100	Throttle Wire	1	
23	0914-80100	Driving Clutch Lever	1	
20,21	0914-75000	Throttle Wire ASSY	1	

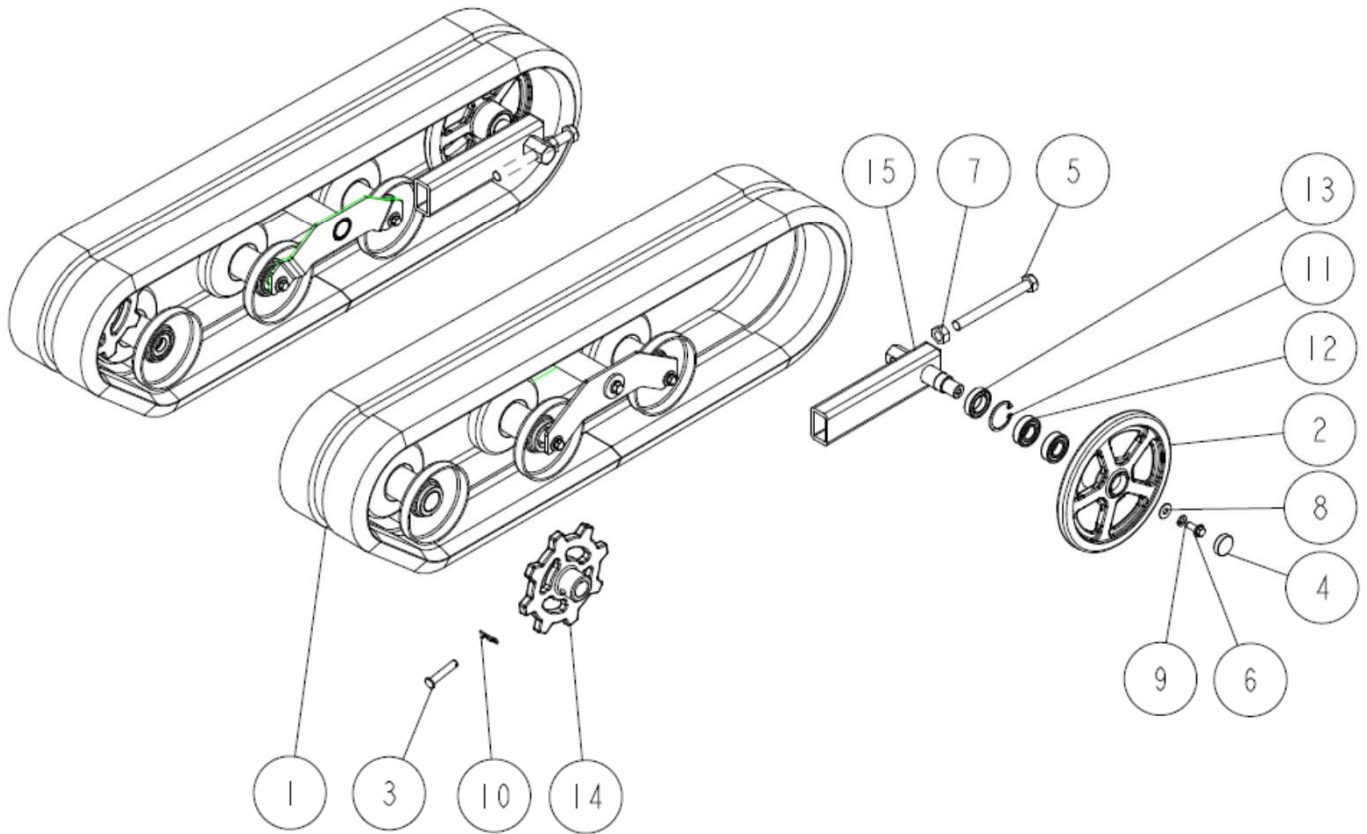

Ref.	Parts Number	Parts Name	Quantity	Remarks
1	80-1920-401-00	Rubber Crawler 160W*60P*35L	2	
2	80-1920-412-00	Idle Roller	2	
3	83-1210-162-00	Round Headed Pin 10*55	2	
4	83-1415-672-00	Blind Cover 30	2	
5	89-1111-141407	Hexagonal Bolt M14*140	2	
6	89-1253-080202	Flange Hexagonal Bolt (8T) M8*20	2	
7	89-1511-140042	Hexagonal Nut M14	2	
8	89-1713-080002	Flat Washer 8	2	
9	89-1750-080002	Spring Washer 8	2	
10	89-2132-100002	Snap Pin 10	2	
11	89-2512-000420	Snap Ring (R42)	2	
12	89-3115-060044	Bearing 6004 2RS	4	
13	89-5121-254210	Oil Seal UE 25.42.10	2	
14	0913-31100	Driving Sprocket	2	
15	0914-30400	Induction Ring Attachment	2	

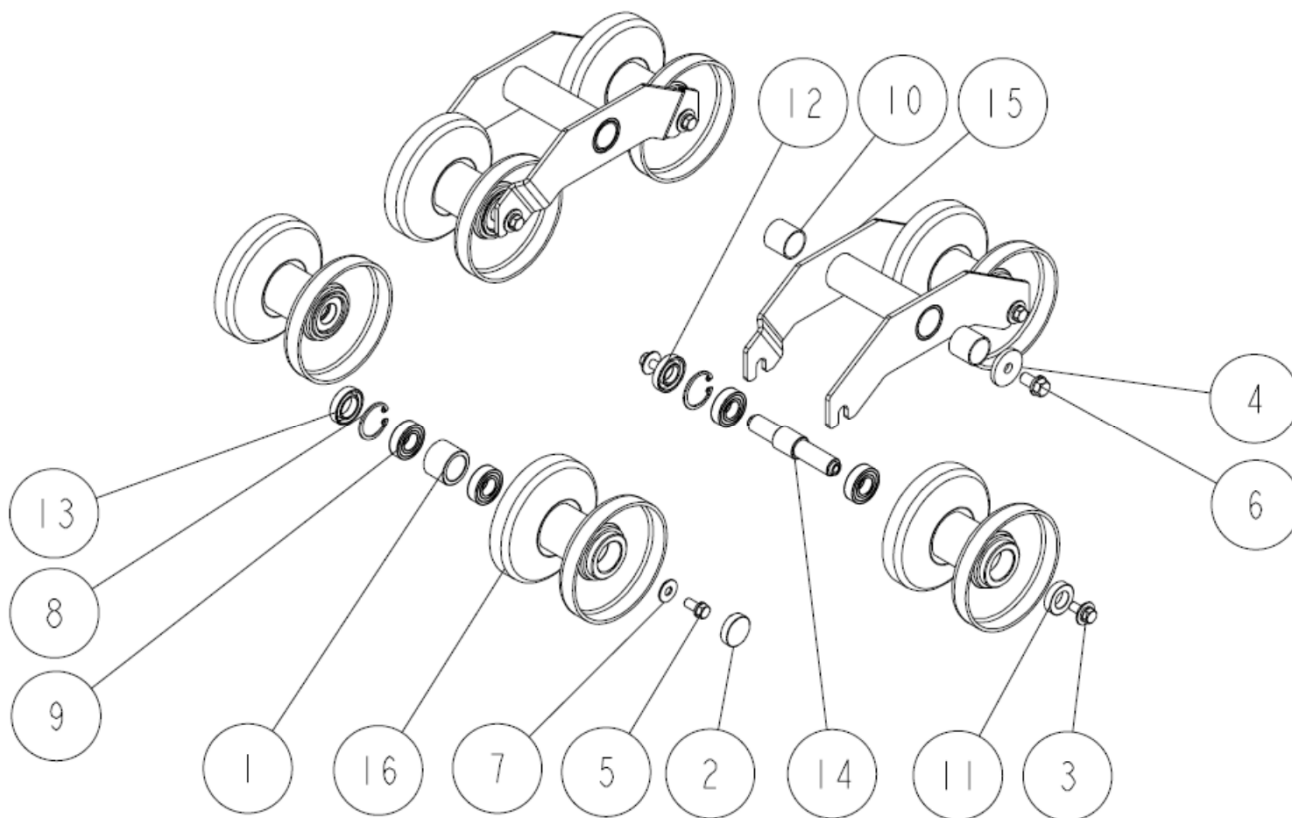

Ref.	Parts Number	Parts Name	Quantity	Remarks
1	80-1920-142-00	Spacer for Turn Wheel	2	
2	83-1415-672-00	Blind Cover 30	2	
3	89-1232-080182	Mini Hexagonal Bolt (SW) M8*18	8	*2)
	89-1233-080202	Mini Hexagonal Bolt (PWSW) M8*20	8	*1) *3)
4	83-1610-321-00	Washer 10*36*4.5	2	
5	89-1232-080182	Mini Hexagonal Bolt (SW) M8*18	2	
	89-1232-080162	Mini Hexagonal Bolt (SW) M8*16	2	*1)
6	89-1232-100202	Mini Hexagonal Bolt (SW) M10*20	2	
7	89-1713-080002	Flat Washer 8 (large)	2	
8	89-2512-000350	Snap Ring (R35)	6	
9	89-3115-060034	Bearing 6003 2RS	12	
10	89-3511-025250	DU Bush 25.25.36F	4	*2)
	89-3510-025250	DU Bush 25.25	4	*1) *3)
11	89-5121-173008	Oil Seal UE 17.30.8	4	
12	89-5121-173507	Oil Seal UE 17.35.7	4	
13	89-5121-203508	Oil Seal UE 20.35.8	2	
14	0914-30200	Shaft for Turn Wheel Setting	4	
15	0914-30300	Turn Wheel Setting	2	
16	0914-30500	Turn Wheel	6	

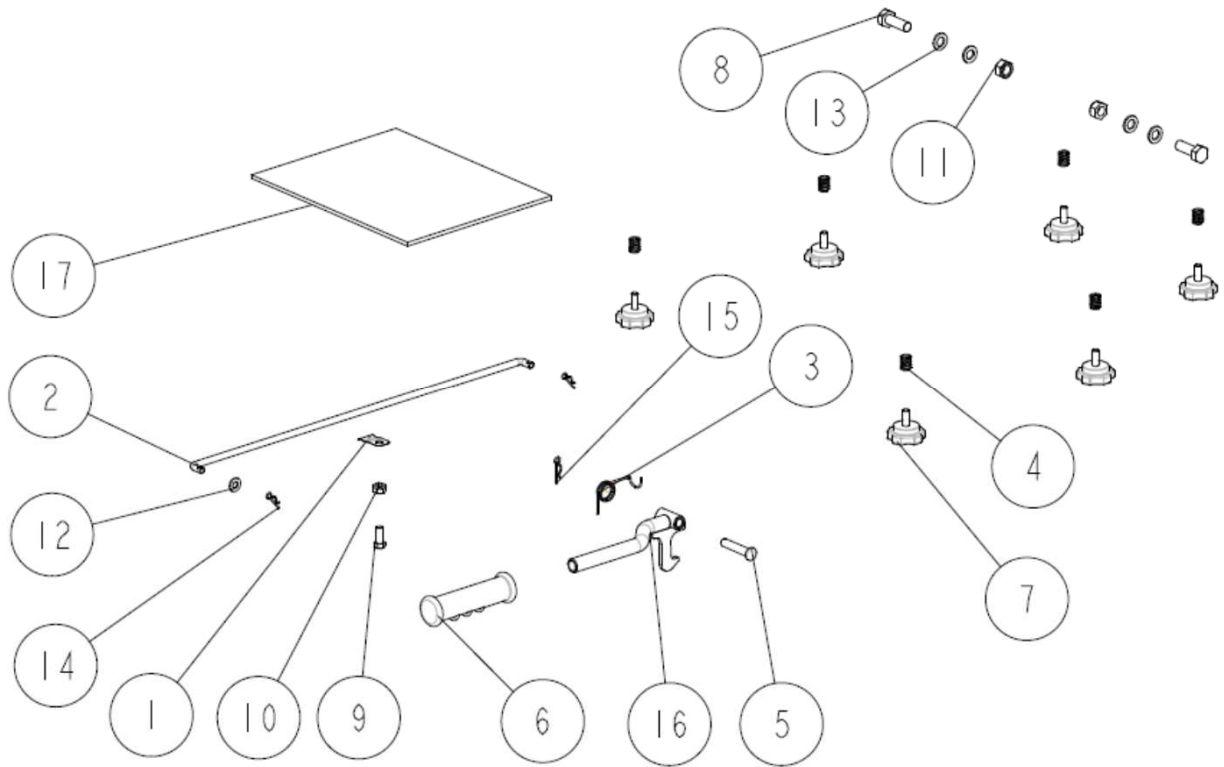

Ref.	Parts Number	Parts Name	Quantity	Remarks
1	80-1920-674-00	Fix Spring	1	
2	80-1920-711-00	Platform Support Bar	1	
3	80-1920-716-00	Platform Lock Spring	6	
4	80-1920-717-00	Knob Spring for Platform	6	
5	83-1210-162-00	Round Headed Pin 10*55	1	
6	83-1654-433-00	Lock Lever Grip	1	
7	83-1920-102-00	Knob Bolt M8*20	6	
8	89-1113-120352	Hexagonal Bolt (8T) M12*35	2	
9	89-1211-080202	Mini Hexagonal Bolt M8*20	1	
10	89-1541-080003	Mini Hexagonal Nut (SW) M8	1	
11	89-1551-120002	Hexagonal U Nut M12	2	
12	89-1711-080002	Flat Washer 8	1	
13	89-1711-120002	Flat Washer 12	4	
14	89-2131-080002	Snap Pin 8	2	
15	89-2131-100002	Snap Pin 10	1	
16	0914-61100	Platform Stopper	1	
17	0914-70200	Insulation Plate(230*290)	1	

UA07G00043~

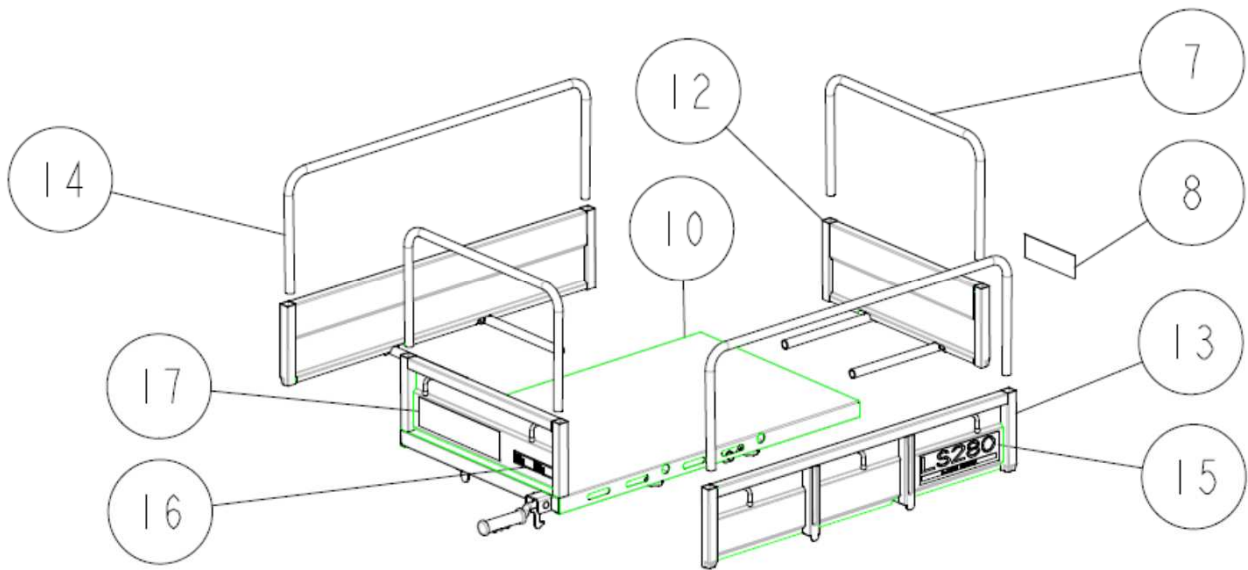

~UA07G00042

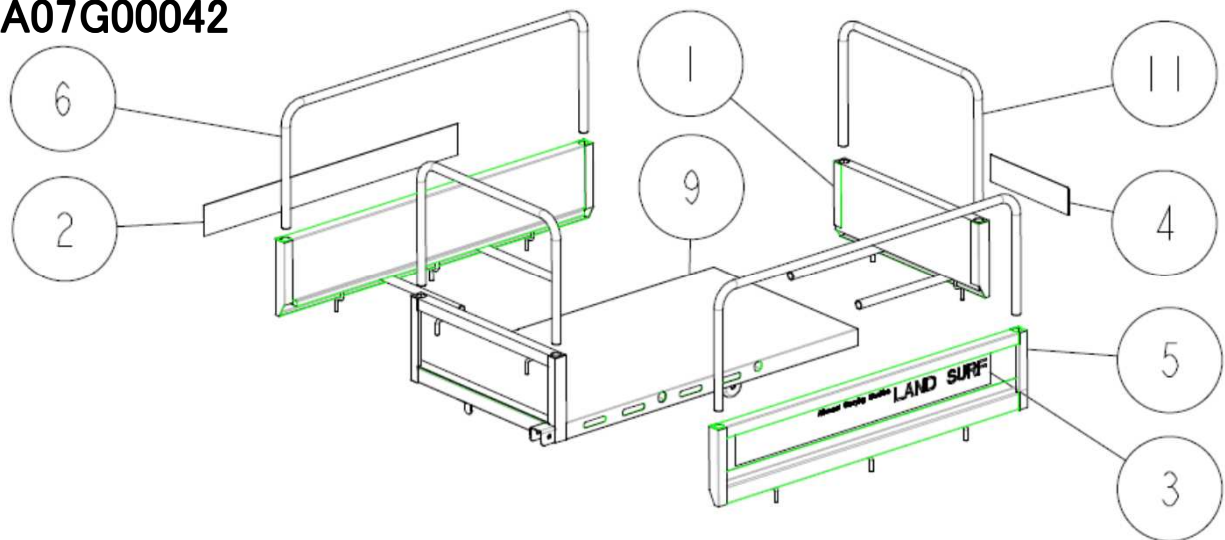

Ref.	Parts Number	Parts Name	Quantity	Remarks
1	80-1920-725-20	Front Frame	1	*7)
2	80-1920-904-00	LS Label (L)	1	*7)
3	80-1920-905-00	LS Label (R)	1	*7)
4	80-1920-906-00	Label,OREC	1	*7)
5	80-1923-724-00	Side Frame for Platform	2	*7)
6	80-1923-734-00	Side Pipe for Platform	2	*7)
7	80-1923-735-10	Front Frame Pipe	2	*6)
8	0913-73200	Label,OREC	1	*6)
9	0914-60100	Platform	1	*7)
10	0914-60110	Platform	1	*6)
11	0914-60200	Front Frame Pipe	2	*7)
12	0914-60300	Front Frame	1	*6)
13	0914-60400	Side Frame for Platform	2	*6)
14	0914-61200	Side Pipe for Platform	2	*6)
15	0914-77110	Label,Model LS280	2	*6)
16	0914-77400	Label, Loading Capacity 250	1	*6)
17	0919-71700	Label, Caution (Large)	1	*6)