

Parts catalogue

BUSH CUTTER

(EXPORT MODEL)

SH50

SH50C

SH50C(2Action)

MODEL	CODE NO.
SH50	0206-ΔΔΔΔΔ
SH50C	0206-ΔΔΔΔΔ

CONTENTS

Fig.1	HANDLE-----	1
Fig.2	TRANSMISSION-----	3
Fig.3	FRAME & FRONT WHEEL-----	5
Fig.4	GEAR BOX, ROTARY COVER & TIRE-----	9

OREC CO.,LTD.

Fig. 1 HANDLE

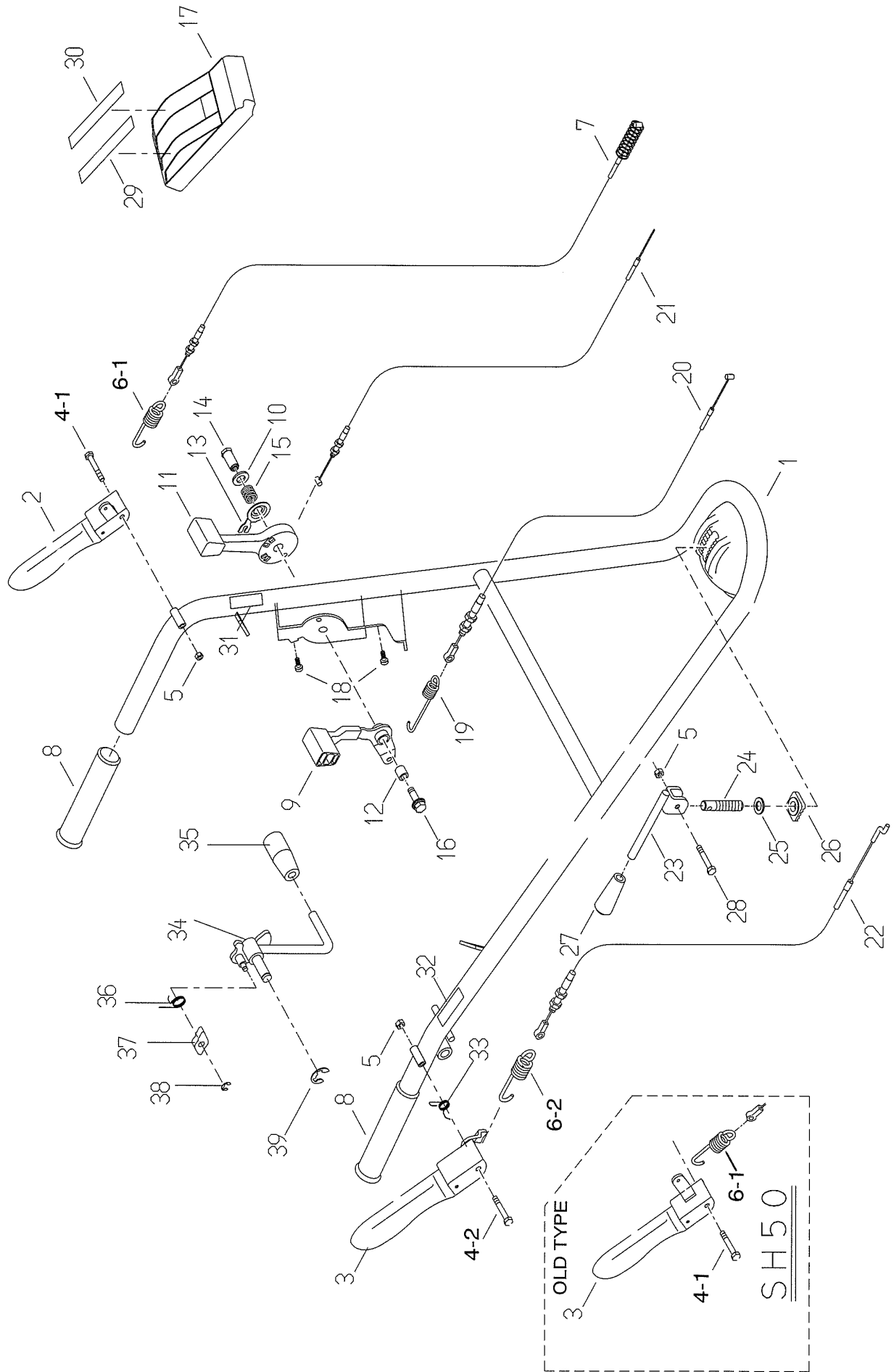

Fig.1 HANDLE

Ref.	Parts No.	Parts Name	Quantity		(2Action)	Remarks
			SH50 GX160	SH50C GX160	SH50C GX160	
1	0206-10110	Handle	1	1		*4)
	0206-10200	Handle			1	*5)
2	0203-10200	Driving Clutch Lever	1	1	1	
3	0203-10300	Knife Clutch Lever	1	1		*4)
	0206-10300	Knife Clutch Lever			1	*5)
4-1	89-1111-060402	Hexagonal Bolt M6*40	2	2	1	
4-2	89-1113-060452	Hexagonal Bolt M6*45			1	*5)
5	89-1551-060002	U Nut M6	3	3	3	
6-1	80-1515-966-00	Clutch Spring	2	2	1	
6-2	80-1417-966-00	Clutch Spring			1	*5)
7	0201-70200	Driving Clutch Wire	1	1	1	
8	83-1515-411-00	Grip	2	2	2	
9	80-1022-260-00	Driving Change Lever	1	1	1	
10	89-1711-120003	Flat Washer 12	1	1	1	
11	80-1020-265-00	Throttle Lever	1	1	1	
12	80-1020-270-00	Inner Collar	1	1	1	
13	80-1020-264-00	Control Washer	1	1	1	
14	80-1020-262-00	Control Lever Shaft	1	1	1	
15	80-1020-263-00	Control Lever Shaft Spring	1	1	1	
16	89-1139-080302	Hexagonal Bolt(PWSW) M8*30	1	1	1	
17	80-1020-231-00	Control Cover	1	1	1	
18	89-1161-050122	Tapping Screw with Cross Hole M5*12	2	2	2	
19	80-1020-967-00	Driving Change Spring	1	1	1	
20	0201-70300	Driving Clutch Wire	1	1	1	
21	0203-70200	Throttle Wire	1	1	1	
22	0201-70400	Knife Tension Wire	1	1	1	
23	0203-20400	Handle Fixing Lever	1	1	1	
24	0203-20500	Handle Fixing Bolt	1	1	1	
25	89-1851-120000	Plate Spring M12	2	2	2	
26	80-1516-251-00	Handle Fixing Washer	1	1	1	
27	83-1210-425-00	Lever Grip 10	1	1	1	
28	89-1113-060302	Hexagonal Bolt(8T) M6*30	1	1	1	
29	80-1020-912-00	Label, Driving Shift	1	1	1	*6)
	80-1020-912-10	Label, Driving Shift			1	*1) *7)
30	80-1020-913-00	Label, Throttle(H)	1	1	1	*6)
	80-1020-913-10	Label, Throttle(H)			1	*1) *7)
31	0206-70100	Label, Driving	1	1	1	
32	0206-70300	Label, Blade	1	1		*4)
	0206-70900	Label, Blade			1	*5)
33	0206-70800	Lever return spring			1	*5)
34	0206-10400	Blade tension lever			1	*5)
35	80-1417-255-00	Lever Grip(Red) 10			1	*5)
36	0211-70400	Stopper return spring			1	*5)
37	80-1417-253-00	Stopper			1	*5)
38	89-2521-000050	E Type Ring 5			1	*5)
39	89-2521-000100	E Type Ring 10			1	*5)

MEMO

*1)Interchangeable

*2)Serial Number : ~XT02A00317

*3)Serial Number : XT02J00011~

*4)Serial Number : ~XT02M00094

*5)Serial Number : XT03C00001~

*6)Serial Number : ~XT03G00132

*7)Serial Number : XT03K00133~

***8)Serial Number : ~XT05G00011**

***9)Serial Number : XT05K00012~**

Fig. 2 TRANSMISSION

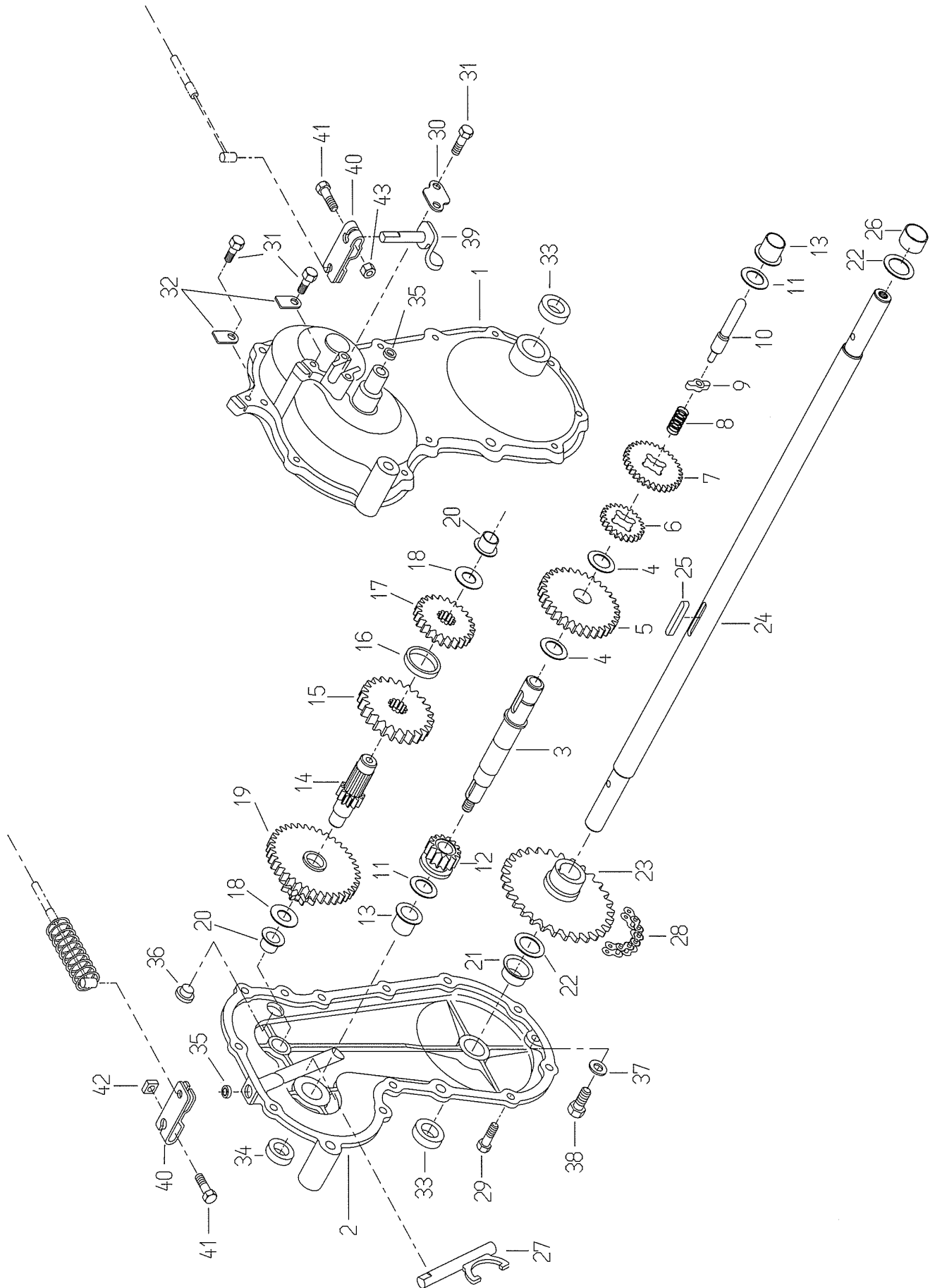

Fig.2 TRANSMISSION

Ref.	Parts No.	Parts Name	Quantity		(2Action)	Remarks
			SH50 GX160	SH50C GX160	SH50C GX160	
1-43	0203-00100	Transmission ASSY	1	1	1	
1	0203-00200	Transmission Case (L)	1	1	1	
2	0203-00300	Transmission Case (R)	1	1	1	*8)
	0203-00310	Transmission Case (R)			1	*9)
3	80-1516-118-00	Main Shaft	1	1	1	
4	83-1020-363-00	Thrust Washer 16*24*1	2	2	2	
5	80-1515-123-00	Main Shaft Gear 59T	1	1	1	
6	80-1020-123-10	Low Gear	1	1	1	
7	80-1515-122-00	Main Shaft Gear 32T	1	1	1	
8	80-1020-161-00	Driving Shift Spring	1	1	1	
9	80-1020-108-00	Driving Shift Guide	1	1	1	
10	80-1020-107-00	Driving Change Shaft	1	1	1	
11	83-1020-361-00	Thrust Washer 15*24*1	2	2	2	
12	80-1515-119-00	Driving Clutch Gear 15T	1	1	1	
13	89-3511-015150	Collar DU Bush 15*15*23F	2	2	2	
14	80-1516-127-00	2nd Shaft	1	1	1	
15	80-1516-129-00	2nd Shaft 48T	1	1	1	
16	80-1020-122-00	Collar	1	1	1	
17	80-1516-128-00	2nd Shaft 39T	1	1	1	
18	83-1020-355-00	Thrust Washer 12*24*1	2	2	2	
19	80-1515-131-00	2nd Shaft Sprocket 10T	1	1	1	
20	89-3511-012100	Collar DU Bush 12*10*20F	2	2	2	
21	89-3511-018100	Collar DU Bush 18*10*26F	1	1	1	
22	83-1830-368-00	Thrust Washer 18*26*1	2	2	2	
23	0203-00400	30T Sprocket Boss	1	1	1	
24	0203-00500	Axle	1	1	1	
25	89-2150-050350	Key(round) 5*35	1	1	1	
26	89-3510-018120	DU Bush 18*12	1	1	1	
27	80-1515-114-10	Driving Clutch Fork	1	1	1	
28	89-6512-035062	Chain #35-62L	1	1	1	
29	83-1515-148-00	Hexagonal Tap Tight M6*22	12	12	12	
30	80-1515-185-00	Driving Shift Arm Holder	1	1	1	
31	83-1020-148-00	Hexagonal Tap Tight M6*14	4	4	4	
32	80-1515-186-00	Wire Holder	2	2	2	
33	89-5121-183008	Oil Seal UE. 18.30.8	2	2	2	
34	89-5121-152507	Oil Seal UE. 15.25.7	1	1	1	
35	89-5131-081404	Oil Seal UE. 8.14.4	2	2	2	
36	83-1517-685-00	Oil Cap	1	1	1	
37	83-1415-348-00	Packing 8.5*16*1.3	1	1	1	
38	83-1020-143-00	Hexagonal Tap Tight M8*18	1	1	1	
39	80-1515-106-00	Driving Shift Arm	1	1	1	
	80-1020-106-00	Driving Shift Arm			1	*1)
40	80-1020-193-10	Driving Change Arm	2	2	2	
41	89-1144-060253	Hexagonal Bolt with Cross Hole(PW.SW)	2	2	2	
42	83-1020-198-00	Square Nut M6	1	1	1	
43	89-1511-060043	Hexagonal Nut M6	1	1	1	

MEMO

Fig. 3 FRAME & FRONT WHEEL

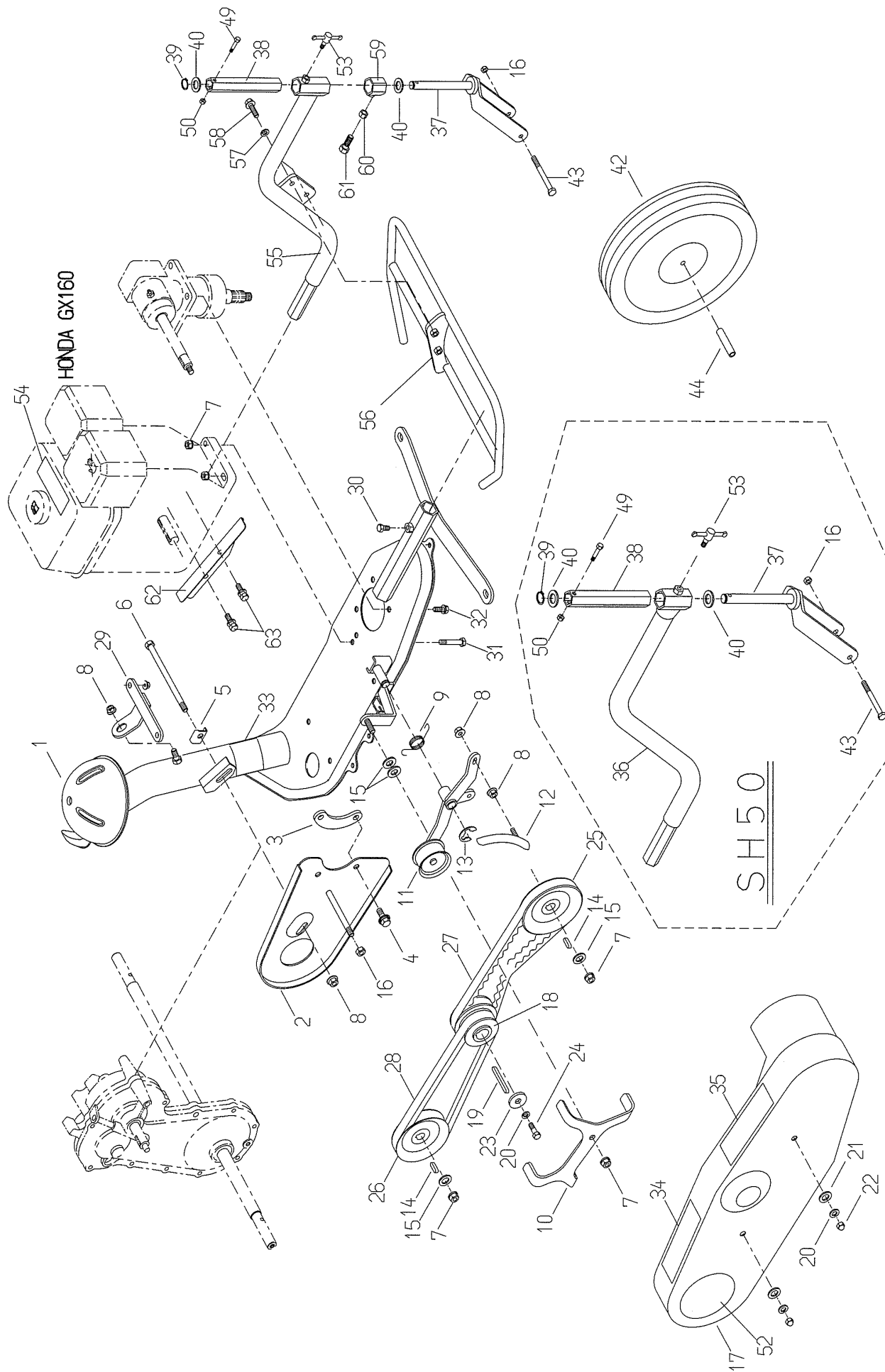

Fig.3 FRAME & FRONT WHEEL

Ref.	Parts No.	Parts Name	Quantity		(2Action)	Remarks
			SH50 GX160	SH50C GX160	SH50C GX160	
1	0206-20110	Engine Frame	1	1	1	
2	0203-60100	Belt Cover Inside	1	1	1	
3	80-1516-509-00	Belt Cover Inside Spacer	1	1	1	
4	89-1233-080202	Mini Hexagonal Bolt(PWSW) M8*20	2	2	2	
5	80-1517-507-00	Metal Holder	1	1	1	
6	89-1213-081052	Mini Hexagonal Bolt(8T) M8*105	1	1	1	
7	89-1543-080002	Mini Hexagonal Nut(SW) M8	7	7	7	
8	89-1631-080042	Flange Mini Hexagonal Nut M8	4	4	4	
9	80-1515-547-00	Knife Tension Return Spring	1	1	1	
10	80-1516-575-00	Belt Holder	1	1	1	
11	0203-20210	Knife Tension Arm	1	1	1	
12	0203-20310	Knife Brake	1	1		
	0203-20320	Knife Brake			1	*1) *5)
13	89-2521-000100	E-Type Snap Ring 10	1	1	1	
14	89-2150-050180	Key(round) 5*18	2	2	2	
15	89-1713-080002	Flat Washer 8	4	4	4	
16	89-1561-080002	Mini U Nut M8	2	2	2	
17	0206-60100	Belt Cover	1	1	1	
18	80-1517-514-10	Engine Pulley(H)	1	1	1	
19	89-2151-050300	Key(half round) 5*30	1	1	1	
20	89-1750-080002	Spring Washer 8	3	3	3	
21	89-1711-080002	Flat Washer 8	2	2	2	
22	89-1671-080042	Mini Bag Nut M8	2	2	2	
23	83-1020-312-00	Washer 8*30*3.2	1	1	1	
24	89-1213-080202	Mini Hexagonal Bolt(8T) M8*20	1	1	1	
25	80-1516-571-00	Knife Pulley	1	1	1	
26	0203-70100	Transmission Pulley	1	1	1	
27	89-6132-002401	V Belt SA24HP II	1	1	1	
28	89-6122-002401	V Belt LA24	1	1	1	
29	0206-20200	Anti-Vibration Stay	1	1	1	
30	89-1211-080162	Mini Hexagonal Bolt M8*16	1	1	1	
31	89-1213-080402	Mini Hexagonal Bolt(8T) M8*40	4	4	4	
32	89-1232-080202	Mini Hexagonal Bolt(SW) M8*20	4	4	4	
33	Not for Sale	Label, Serial Number	1	1	1	
34	80-1488-928-00	Label, Caution for Belt Involving	1	1	1	*6)
	80-1488-928-10	Label, Caution for Belt Involving			1	*1) *7)
35	83-1488-907-00	Label, Caution for Slope	1	1	1	*6)
36	0206-30210	Front Wheel Arm	1	1	1	*2)
37	0206-30320	Front Wheel Fork	1	1	1	
38	0206-30410	Front Wheel Fork Bracket	1	1	1	
39	89-2511-000160	Snap Ring 16	1	1	1	
40	83-1020-363-00	Thrust Washer 16*24*1	2	2	2	
42	80-1517-727-00	Front Wheel	1	1	1	
43	89-1213-080802	Mini Hexagonal Bolt(8T) M8*80	1	1	1	
44	80-1517-728-00	Front Wheel Collar	1	1	1	
49	89-1113-060352	Hexagonal Bolt(8T) M6*35	1	1	1	
50	89-1551-060002	U Nut M6	1	1	1	
52	0203-71000	Label, Belt Cover	1	1	1	
53	83-1210-484-00	Free Handle M8*20	1	1	1	
54	83-1415-909-00	Sticker for Engine (Z18-6)	1	1	1	*6)
	0223-76200	Sticker for Engine			1	*1) *7) *8)
	0214-72100	Sticker for Engine			1	*1) *9)
55	0206-30220	Front Wheel Arm		1	1	*1) *3)
56	0206-80600	Front Guard CMP		1	1	*3)
57	89-1750-080002	Spring Washer 8		2	2	*3)

Fig. 3 FRAME & FRONT WHEEL

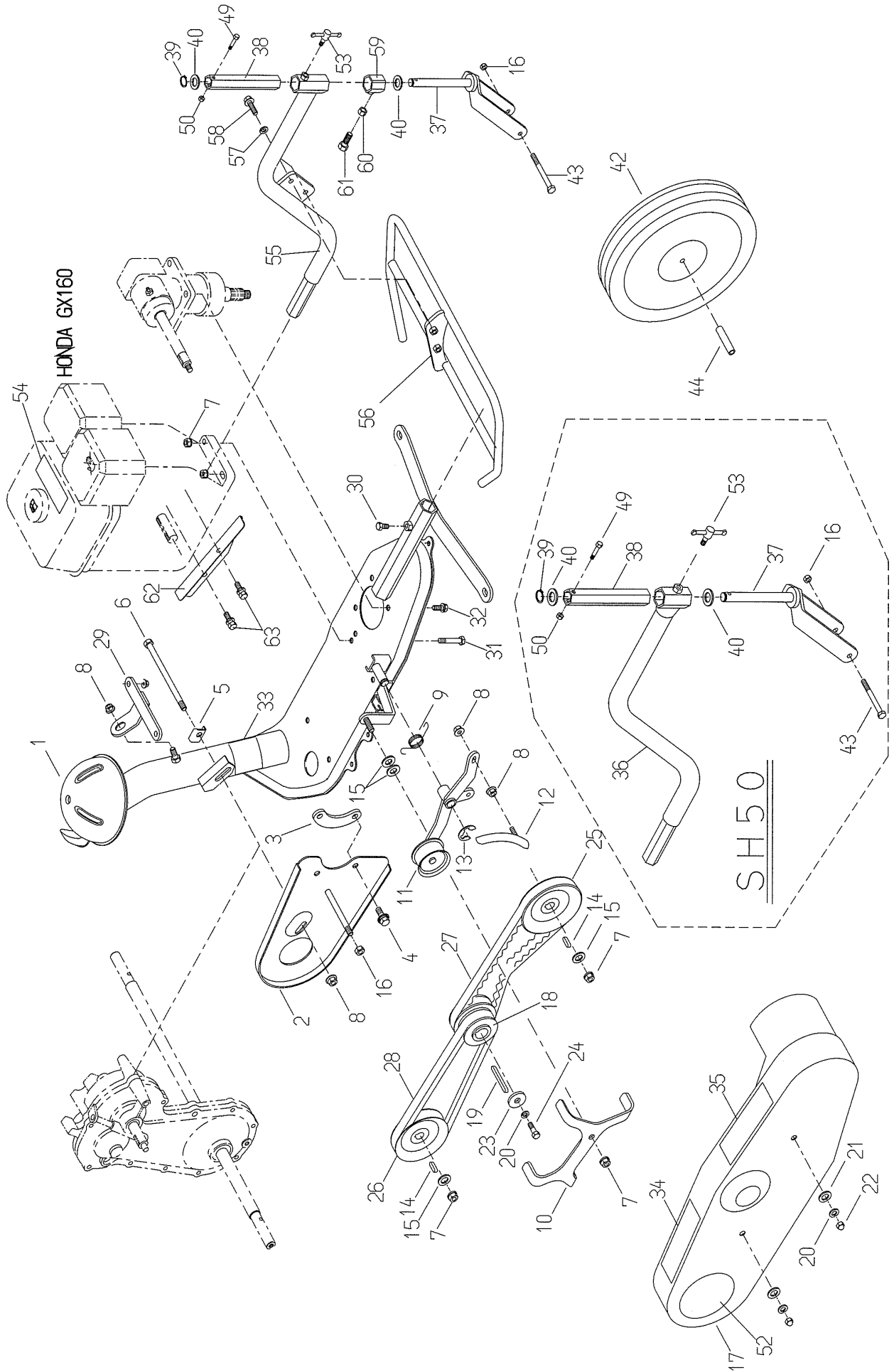

Fig.3 FRAME & FRONT WHEEL

Ref.	Parts No.	Parts Name	Quantity		(2Action)	Remarks
			SH50 GX160	SH50C GX160	SH50C GX160	
58	89-1213-080202	Mini Hexagonal Bolt(8T) M8*20		2	2	*3)
59	0206-80200	Cutting Height Stopper CMP		1	1	*3)
60	89-1611-080042	Mini Hexagonal Nut M8		1	1	*3)
61	89-1213-080252	Mini Hexagonal Bolt(8T) M8*25		1	1	*3)
62	0206-60200	Belt Cover Inside Front(H)			1	*5)
63	89-1232-080122	Mini Hexagonal Bolt(SW) M8*12			2	*5)
64	0223-72900	Attention Mark for Slope			1	*7)
65	0215-83200	Label, Protection Equipment			1	*7)

MEMO

Fig. 4 GEAR BOX . ROTARY COVER & TIRE

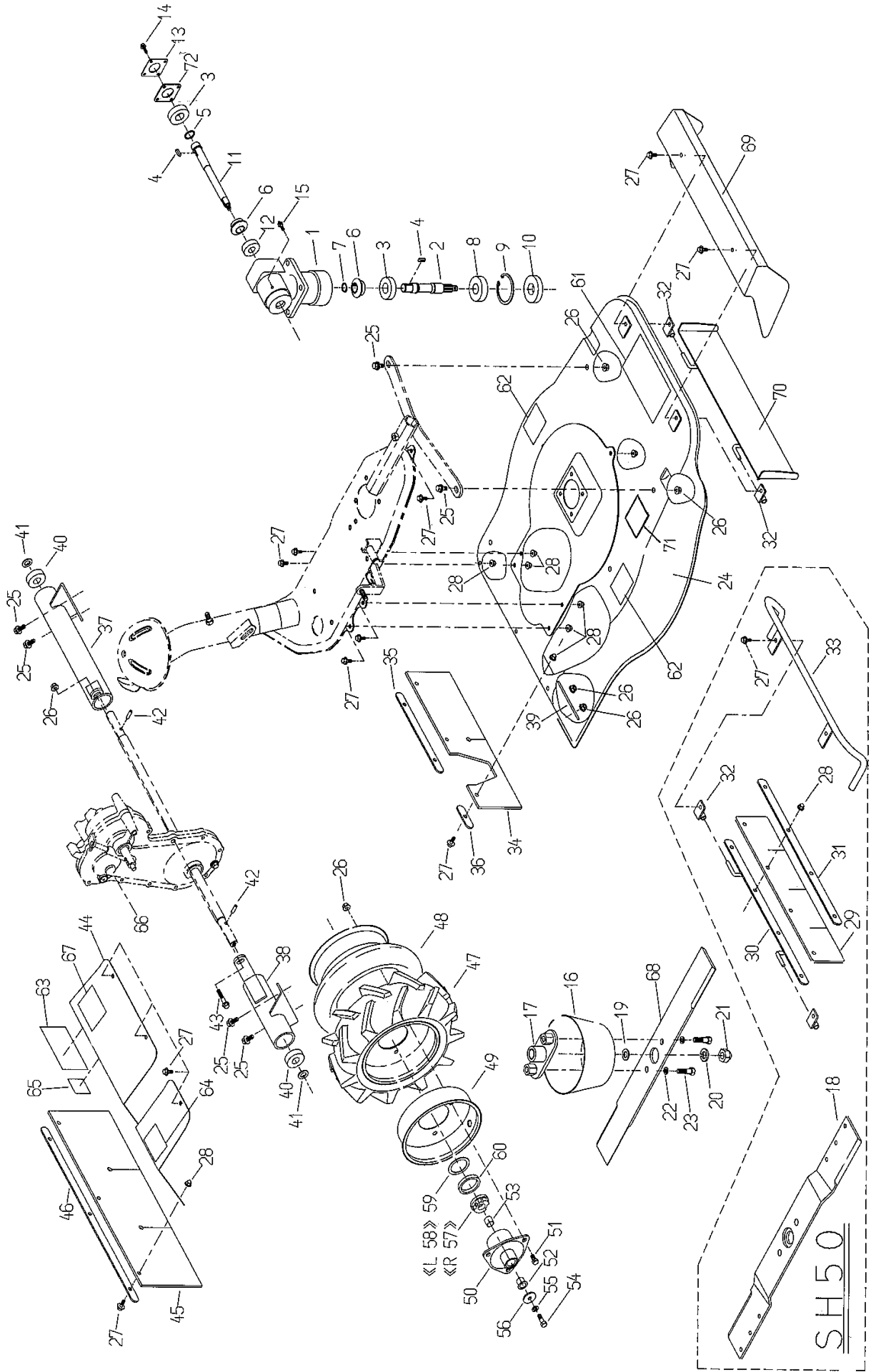

Fig.4 GEAR BOX, ROTARY COVER & TIRE

Ref.	Parts No.	Parts Name	Quantity		(2Action)	Remarks
			SH50 GX160	SH50C GX160	SH50C GX160	
1-15,72	0203-51000	Gear Box ASSY	1	1	1	
1	0203-50100	Gear Box	1	1	1	
2	0203-50300	Vertical Shaft	1	1	1	
3	89-3115-060044	Bearing 6004 2RS	2	2	2	
4	89-2150-050180	Key(round) 5*18	2	2	2	
5	83-1515-626-00	Thrust Washer 22*27*2	1	1	1	
6	80-1517-618-00	Straight Bevel 20T	2	2	2	
7	89-2511-000170	Snap Ring 17	1	1	1	
8	89-3115-062044	Bearing 6204 2RS	1	1	1	
9	89-2512-000470	Snap Ring 47	1	1	1	
10	89-5131-204706	Oil Seal KE 20.47.6	1	1	1	
11	0203-50200	Horizontal Shaft	1	1	1	
12	89-3115-062024	Bearing 6202 2RS	1	1	1	
13	80-1515-607-00	Gear Box Cap B	1	1	1	
14	83-1020-148-00	Hexagonal Tap Tight M6*14	4	4	4	
15	83-1415-975-00	Grease Nipple M6	1	1	1	
16	80-1035-836-00	Knife Neck Guard	1	1	1	
17	0203-50610	Knife Bracket	1	1	1	
18	80-1035-821-00	Blade	1	1	1	*2)
19	89-1711-120002	Flat Washer 12	1	1	1	
20	89-1750-120002	Spring Washer 12	1	1	1	
21	0203-70800	Bag Nut(slender) M12	1	1	1	
22	89-1750-100002	Spring Washer 10	2	2	2	
23	89-1254-100252	Flange Hexagonal Bolt(slender) M10*25	2	2	2	
24	0203-50510	Rotary Cover	1	1	1	
25	89-1233-080202	Mini Hexagonal Bolt(PWSW) M8*20	6	6	6	
26	89-1631-080042	Flange Mini Hexagonal Nut M8	13	13	13	
27	89-1137-060152	Hexagonal Bolt(PW) M6*15	20	20	20	
28	83-1575-189-00	Flange Bag Nut M6	20	20	20	
29	80-1035-734-00	Front Flapper	1	1	1	*2)
30	80-1035-735-00	Front Flapper Setting	1	1	1	*2)
31	80-1035-736-00	Front Flapper Holder	1	1	1	*2)
32	80-1035-737-00	Flapper Shaft Receiver	2	2	2	
33	0206-80100	Foot Guard	1	1	1	*2)
34	0203-60600	Flapper B	1	1	1	
35	0203-60700	Flapper Holder A	1	1	1	
36	0203-60800	Flapper Holder B	1	1	1	
37	0203-60300	Axle Cover(L)	1	1	1	
38	0203-60400	Axle Cover(R)	1	1	1	*8)
	0203-60410	Axle Cover(R)			1	*9)
39	0203-60500	Axle Reinforcing Plate	2	2	2	
40	89-3115-062024	Bearing 6202 2RS	2	2	2	
41	83-1020-361-00	Thrust Washer 15*24*1	2	2	2	
42	89-2142-050250	Parallel Pin 5*25	2	2	2	
43	89-1251-080502	Flange Mini Hexagonal Bolt M8*50	1	1	1	
44	0203-60910	Transmission Cover	1	1	1	
45	0203-61000	Flapper A	1	1	1	
46	0203-61100	Flapper Holder C	1	1	1	
47-49	80-1515-411-00	Tire ASSY(without Boss)	2	2	2	
47	80-1515-401-00	Tire(3.25*5)	2	2	2	
48	80-1515-404-00	Tube	2	2	2	
49	80-1515-407-00	Wheel	2	2	2	
50	0203-30700	Wheel Boss	2	2	2	
51	89-1211-080162	Mini Hexagonal Bolt M8*16	6	6	6	
52	89-3511-015150	Collar DU Bush 15.15.23F	2	2	2	
53	89-3510-015150	DU Bush 15.15.	2	2	2	

Fig. 4 GEAR BOX . ROTARY COVER & TIRE

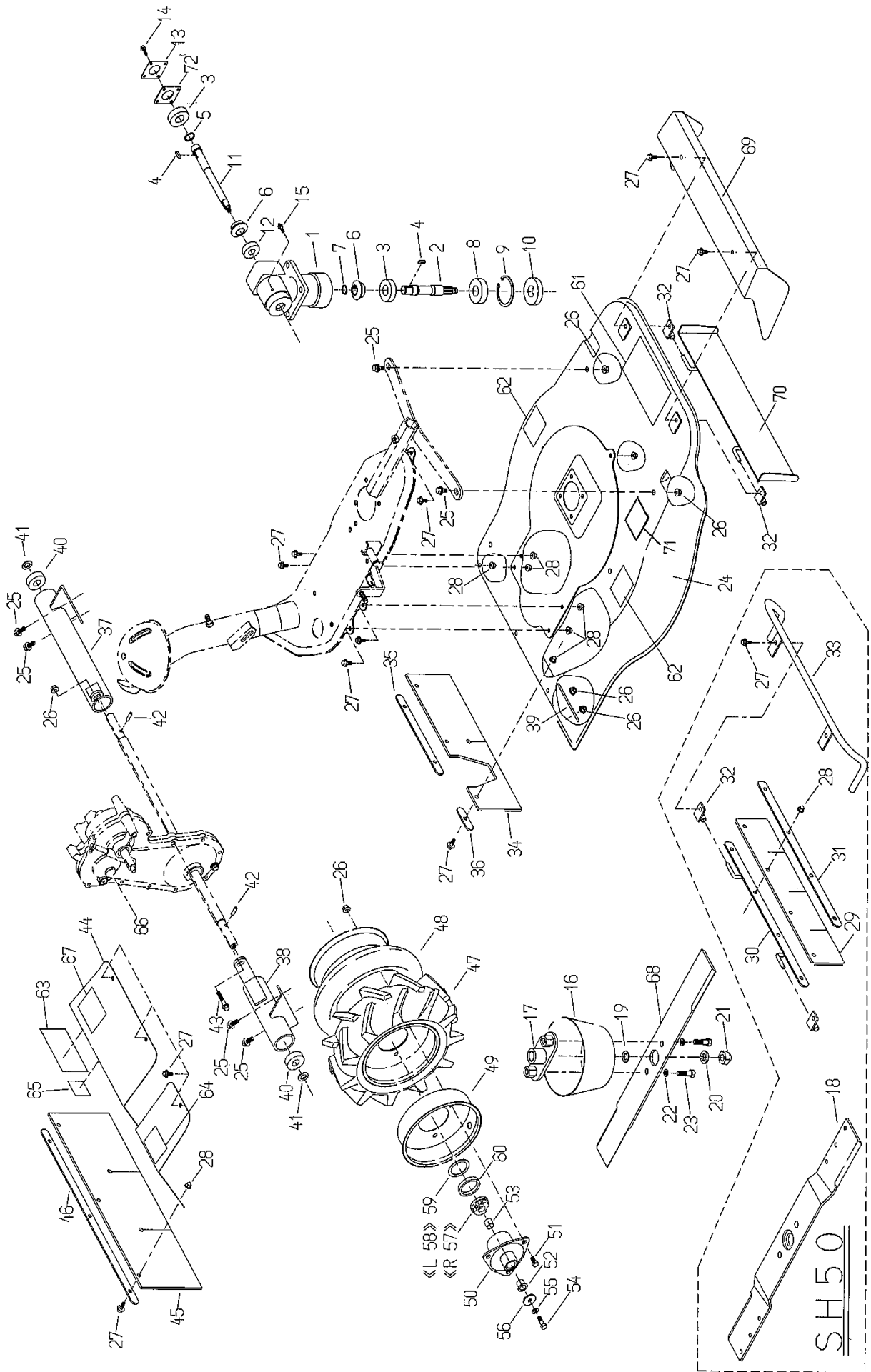

Fig.4 GEAR BOX, ROTARY COVER & TIRE

Ref.	Parts No.	Parts Name	Quantity		(2Action)	Remarks
			SH50 GX160	SH50C GX160	SH50C GX160	
54	89-1213-080252	Mini Hexagonal Bolt(8T) M8*25	2	2	2	
55	89-1750-080002	Spring Washer 8	2	2	2	
56	83-1020-312-00	Washer 8*30*3.2	2	2	2	
57	80-1020-459-00	Ratchet(R)	1	1	1	
58	80-1020-458-00	Ratchet(L)	1	1	1	
59	0203-70600	Felt Spacer	2	2	2	
60	0203-70400	Clutch Guide Seal	2	2	2	
61	0203-71100	Label, Main (Shuttle Mower)	1	1	1	
62	80-1488-926-00	Label, Caution for Knife	2	2	2	*6)
	80-1488-926-10	Label, Caution for Knife			2	*1) *7)
63	80-1484-A47-00	Label, Caution (large)	1	1	1	*6)
	0223-76100	Label, Caution (large)			1	*1) *7)
64	83-1415-913-00	Label, Protection for Eyes	1	1	1	*6)
65	80-1010-933-00	Label, CE	1	1	1	
66	83-1516-916-00	Label, Gear Oil	1	1	1	
67	0203-70700	Label SH50	1			*2)
	0206-70400	Label SH50C		1	1	*3)
68	0214-70700	Blade		1	1	*1) *3) *8)
	0214-70710	Blade			1	*1) *9)
69	0206-80700	Front Side Cover		1	1	*1) *3)
70	0214-60200	Front Flapper CMP		1	1	*1) *3)
71	83-1415-912-10	Label, Caution for Hitting Object			1	*7)
72	0219-73100	Gear Box Packing			1	*9)

MEMO