

# Parts catalogue

## LAWN MOWER

(EXPORT MODEL)

**GR481(2Action)**

**GR531(2Action)**

**GR532(2Action)**

MODEL	CODE
GR481	80-1012-ΔΔΔ-00
GR531	80-1022-ΔΔΔ-00
GR532	80-1023-ΔΔΔ-00

### CONTENTS

Fig.1	GEAR CASE-----	1
Fig.2	GEAR CASE INSIDE, OUTSIDE-----	3
Fig.3	SAFETY COVER-----	5
Fig.4	FRONT WHEEL, REAR WHEEL-----	9
Fig.5	HANDLE-----	13
Fig.6	BLAD AND BAG-----	17

**OREC CO.,LTD.**

*Update : December 2005*

Fig 1 Gear Case

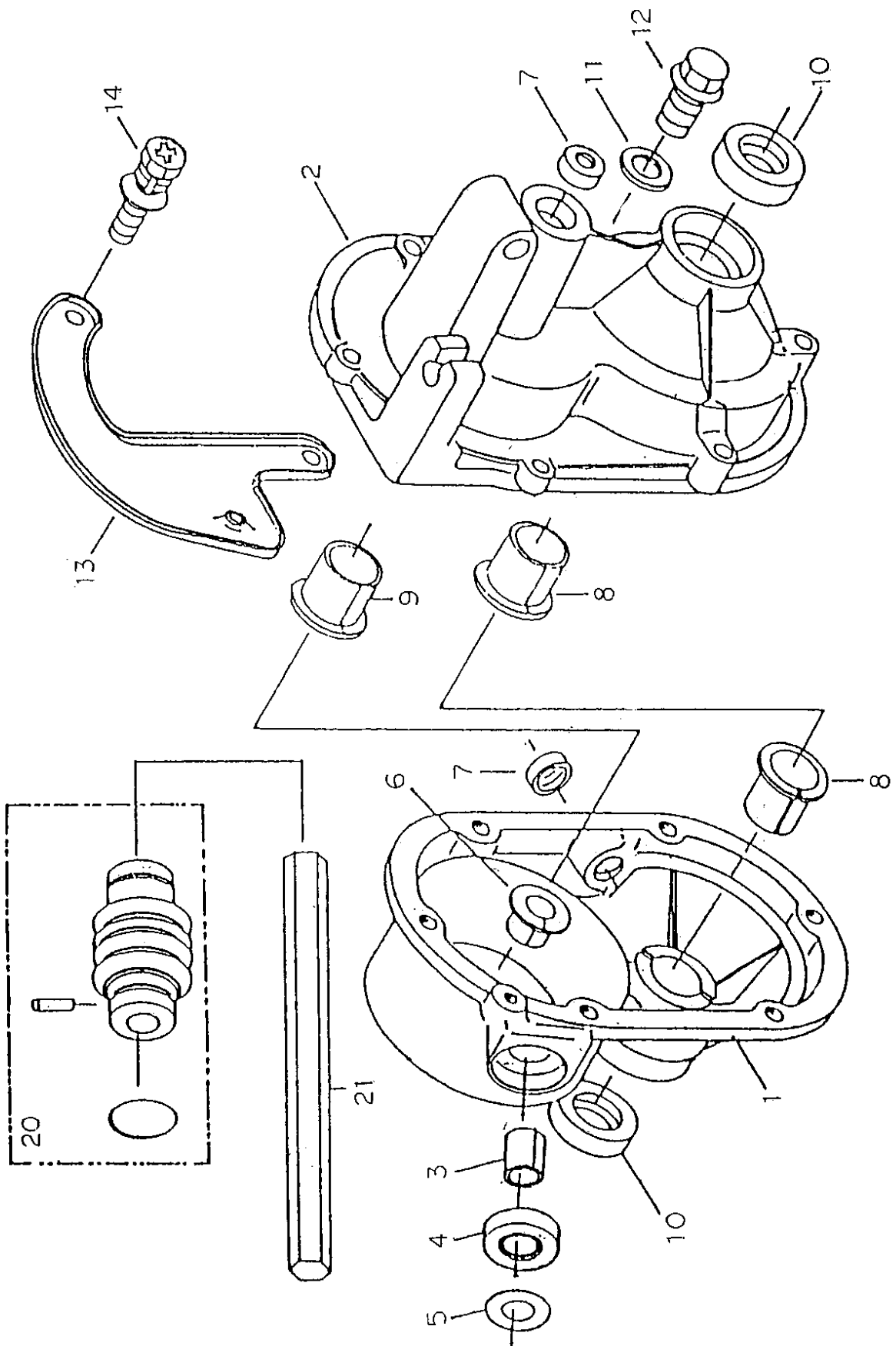

**Fig 1 Gear Case**

Ref.	Parts No.	Parts Name	C2 (2Action Type)												Remarks	
			GR481				GR531				GR532					
			D	D	C	C2	D	D	C	C2	D	D	DT	C		C2
			FC 150	GXV 120	GXV 120	GXV 120	FC 150	GXV 160	GXV 160	GXV 160	FC 150	GXV 160	GXV 160	GXV 160		GXV 160
	80-1020-100-00	Gear Case Assy(Pin Type)	1	1	1	1	1	1	1	1	1	1	1	1	Note 1	
	<b>0230-00000</b>	<b>Gear Case Assy(Key Type)</b>													<b>*11) *12)</b>	
1	80-1020-101-00	Gear Case (Inside)	1	1	1	1	1	1	1	1	1	1	1	1		
2	80-1020-103-00	Gear Case (Outside)	1	1	1	1	1	1	1	1	1	1	1	1		
3	89-3512-010150	DBB Bush 10.15	1	1	1	1	1	1	1	1	1	1	1	1		
4	89-5121-102007	Oil Seal UE 10207	1	1	1	1	1	1	1	1	1	1	1	1		
5	83-1210-352-00	Thrust Washer 10*22*1.0	1	1	1	1	1	1	1	1	1	1	1	1		
6	89-3511-012100	DU Bush 12*10*20F	1	1	1	1	1	1	1	1	1	1	1	1		
7	89-5131-081404	Oil Seal KE8.14.4	2	2	2	2	2	2	2	2	2	2	2	2		
8	89-3511-015150	DU Bush 15*15*23F	2	2	2	2	2	2	2	2	2	2	2	2		
9	89-3511-016150	DU Bush 16*15*24F	1	1	1	1	1	1	1	1	1	1	1	1		
10	89-5121-152507	Oil Seal UE 15.25.7	2	2	2	2	2	2	2	2	2	2	2	2		
11	83-1020-349-00	Packing 10.5*18*1.6	1	1	1	1	1	1	1	1	1	1	1	1		
12	89-1254-100143	Flange Mini Bolt M10*1.25*1	1	1	1	1	1	1	1	1	1	1	1	1		
13	80-1020-198-10	Lock Arm Bracket B	1	1	1	1	1	1	1	1	1	1	1	1		
14	89-1144-060223	Hexagonal Bolt(PWSW) M6*	6	6	6	6	6	6	6	6	6	6	6	6		
20	80-1020-515-00	Universal Joint NC-10-37C1	2	2	2	2	2	2	2	2	2	2	2	2		
21	80-1020-522-10	Drive Shaft K 97L	1				1				1				*2)	
	80-1020-525-00	Drive Shaft H 122L		1	1	1									*3)	
	80-1020-526-00	Drive Shaft H 136L						1	1	1		1	1	1	*4)	

MEMO

Note 1: Transmission ASSY consists from parts 1 to20(this page)  
and 1 to 24(next page).

\*1) Interchangeable

\*2) Engine : FC150V

\*3) Engine : GXV120

\*4) Engine : GXV160

\*5) Serial Number : GR532D : ~VE96F00031 GR481D : ~VF96F00014

\*6) Serial Number : GR532D : VE97A00032~ GR531D : VD98C00001~ GR481D : VF97C00001~

\*7) Serial Number : GR532D : ~VH02E00310 GR531D : ~VG02E00130 GR481D : ~VQ02E00086

\*8) Serial Number : GR532D : VH02K00391~ GR531D : VG02L00136~ GR481D : VQ02K00107~

\*9) Serial Number : GR532D : ~VH02L00992 GR531D : ~VG02M00929 GR481D : ~VQ02M00376

\*10)Serial Number : GR532D : VH03C00001~ GR531D : VG03C00006~ GR481D : VQ03K00001~

\*11)Serial Number : GR531D : VG03G00416~

\*12)Only for steel wheel type

\*13)Serial Number : GR532D : VH03J00323~ GR531D : VG03K00526~ GR481D : VQ03K00001~

\*14)Serial Number : GR532D : ~VH03D00274 GR531D : ~VG03H00525 GR481D : ~VQ02M00376

\*15)Serial Number : GR532D : VH04J00024~ GR531D : VG04J00001~

\*16)Serial Number : GR532D : ~VH04D00011 GR531D : ~VG04B02270

\*17)Serial Number : GR532D : VH04L00174~ GR531D : VG04M00421~

\*18)Serial Number : GR532D : ~VH04K00173 GR531D : ~VG04J00120

\*19)Serial Number : GR532D : VH05K00451~ GR531D : VG05K01341~

\*20)Serial Number : GR532D : ~VH05J00450 GR531D : ~VG05H01175

Fig 2 Gear Case (Inside, Outside)

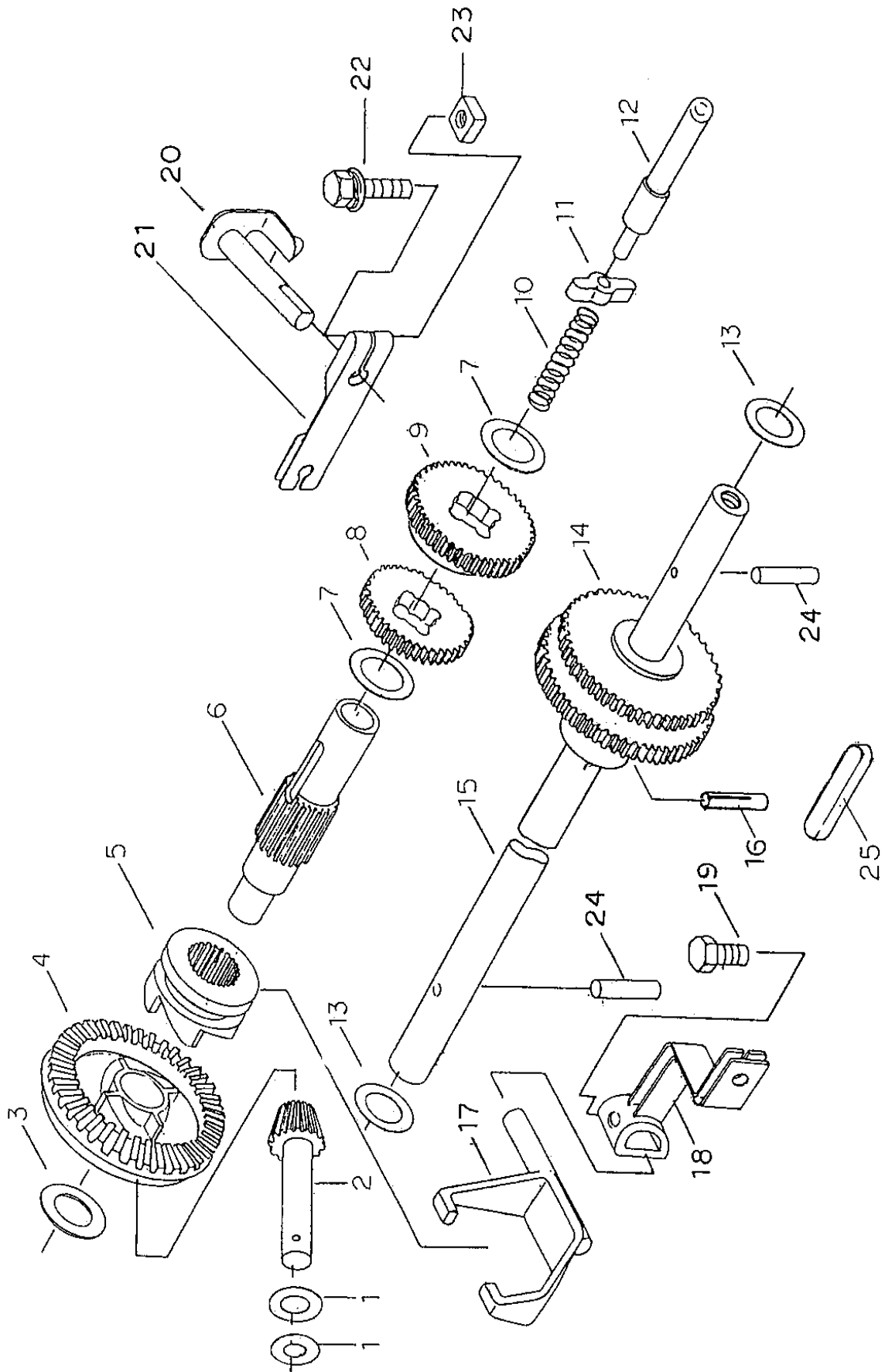
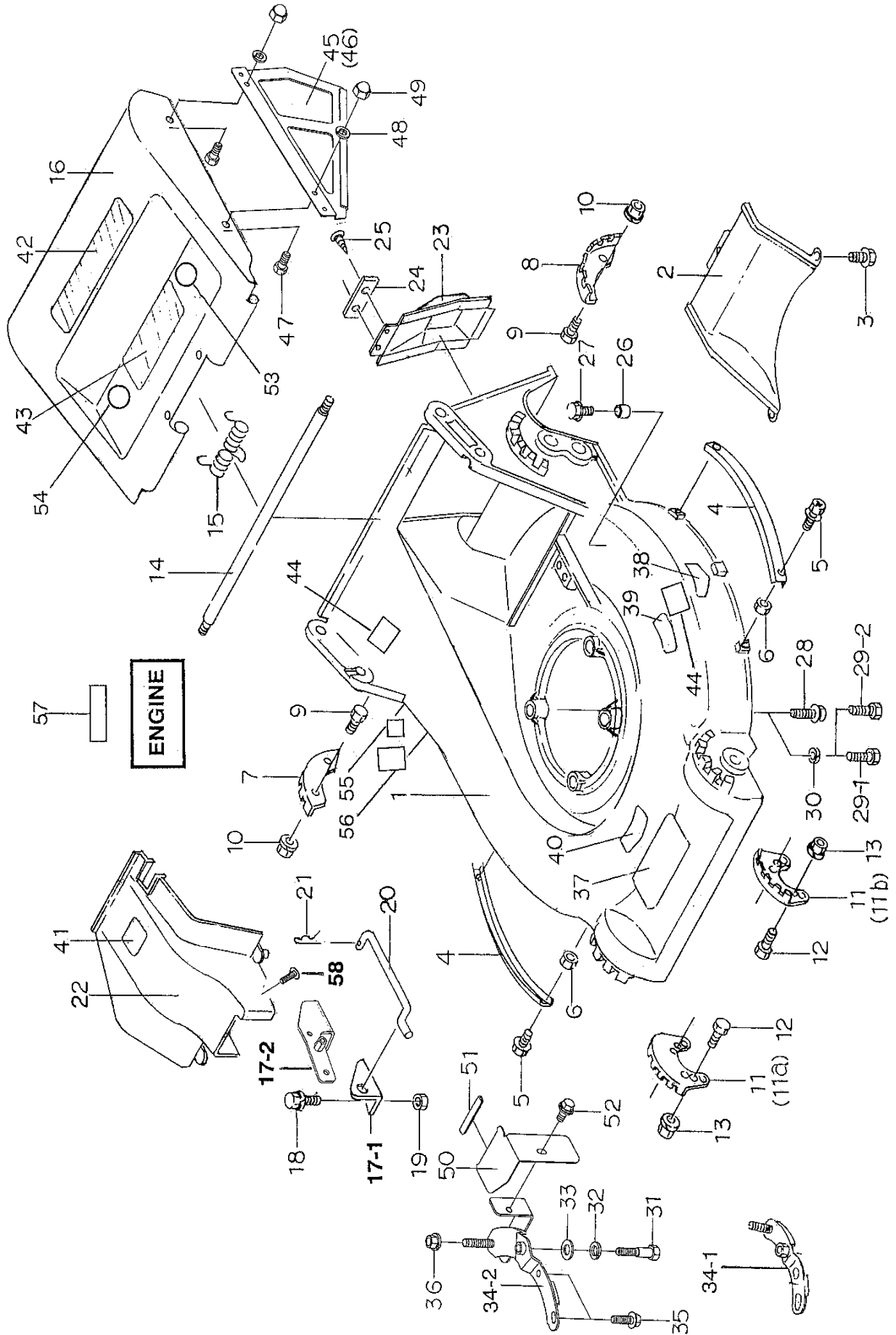

**Fig 2 Gear Case (Inside, Outside)**

Ref.	Parts No.	Parts Name	C2 (2Action Type)												Remarks	
			GR481				GR531				GR532					
			D	D	C	C2	D	D	C	C2	D	D	DT	C		C2
			FC 150	GXV 120	GXV 120	GXV 120	FC 150	GXV 160	GXV 160	GXV 160	FC 150	GXV 160	GXV 160	GXV 160		GXV 160
1	83-1020-351-00	Thrust Washer 10	2	2	2	2	2	2	2	2	2	2	2	2		
2,4	80-1020-115-10	Pinion Bevel&Bevel Gear As	1	1	1	1	1	1	1	1	1	1	1	1		
2	80-1020-116-10	Pinion Bevel	1	1	1	1	1	1	1	1	1	1	1	1		
3	83-1020-355-00	Thrust Washer 12	1	1	1	1	1	1	1	1	1	1	1	1		
4	80-1020-117-10	Bevel Gear 53-tooth	1	1	1	1	1	1	1	1	1	1	1	1		
5	80-1020-119-10	Clutch for Driving	1	1	1	1	1	1	1	1	1	1	1	1		
6	80-1020-118-20	Main Shaft	1	1	1	1	1	1	1	1	1	1	1	1		
7	83-1020-363-00	Thrust Washer 16	2	2	2	2	2	2	2	2	2	2	2	2		
8,9	80-1020-125-10	Gear Assy (Low and High)	1	1	1	1	1	1	1	1	1	1	1	1		
8	80-1020-123-10	Gear (Low)	1	1	1	1	1	1	1	1	1	1	1	1		
9	80-1020-121-10	Gear (High)	1	1	1	1	1	1	1	1	1	1	1	1		
10	80-1020-161-00	Shaft Spring	1	1	1	1	1	1	1	1	1	1	1	1		
11	80-1020-108-00	Change Guide	1	1	1	1	1	1	1	1	1	1	1	1		
12	80-1020-107-00	Change Rod	1	1	1	1	1	1	1	1	1	1	1	1		
13	83-1020-361-00	Thrust Washer 15	2	2	2	2	2	2	2	2	2	2	2	2		
14	80-1020-148-30	Axle Gear(Pin Type)	1	1	1	1	1	1	1	1	1	1	1	1		
	<b>0230-00300</b>	<b>Axle Gear(Key Type)</b>								<b>1</b>					<b>*11) *12)</b>	
15	80-1020-146-00	Axle(Pin Type)	1	1	1	1	1	1	1	1	1	1	1	1		
	<b>0230-00200</b>	<b>Axle(Key Type)</b>								<b>1</b>					<b>*11) *12)</b>	
16	83-1020-157-00	Spring Pin 5*25	1	1	1	1	1	1	1	1	1	1	1	1		
17	80-1020-113-00	Clutch Fork	1	1	1	1	1	1	1	1	1	1	1	1		
18	80-1020-153-10	Clutch Arm	1	1	1	1	1	1	1	1	1	1	1	1		
19	89-1113-060123	Bolt 8T M6x12	1	1	1	1	1	1	1	1	1	1	1	1		
20	80-1020-106-00	Shaft Arm	1	1	1	1	1	1	1	1	1	1	1	1		
21	80-1020-193-10	Change Arm	1	1	1	1	1	1	1	1	1	1	1	1		
22	89-1144-060253	Bolt & PW SW Assy M6*25	1	1	1	1	1	1	1	1	1	1	1	1		
23	83-1020-198-00	Square Nut M6	1	1	1	1	1	1	1	1	1	1	1	1		
24	89-2142-050250	Pin 5*25	2	2	2	2	2	2	2	2	2	2	2	2		
25	<b>89-2150-050330</b>	<b>Key 5*33 (Round)</b>								<b>1</b>					<b>*11) *12)</b>	

MEMO

Fig 3 Safety Cover



**Fig 3 Safety Cover**

Ref.	Parts No.	Parts Name	C2 (2Action Type)												Remarks				
			GR481				GR531				GR532								
			D	D	C	C2	D	D	C	C2	D	D	DT	C		C2			
			FC 150	GXV 120	GXV 120	GXV 120	FC 150	GXV 160	GXV 160	GXV 160	FC 150	GXV 160	GXV 160	GXV 160		GXV 160			
1	80-1010-731-00	Cover (Body) 480	1	1	1	1													
	80-1022-731-00	Cover (Body) 531					1	1	1	1	1	1	1	1	1	1	1	1	
2	80-1010-714-00	Guide 480	1	1	1	1													
	80-1022-714-00	Guide 531					1	1	1	1	1	1	1	1	1	1	1	1	
3	83-1020-143-00	Tapping Bolt M8*18	3	3	3	3													
	83-1020-148-00	Tapping Bolt M6*14					3	3	3	3	3	3	3	3	3	3	3	3	
4	80-1010-741-00	Under Guard 480	2	2	2	2													
5	89-1133-060163	Bolt & PW SW Assy M6*16	4	4	4	4													
6	89-1511-060043	Nut M6	4	4	4	4													
7	80-1022-748-00	Rear Wheel Adjusting Plate(					1	1			1	1							*7)
	80-1023-743-00	Rear Wheel Adjusting Plate(											1						*7)
	0230-20500	Rear Wheel Adjusting Plate(							1	1					1	1			*8)
8	80-1022-747-00	Rear Wheel Adjusting Plate(					1	1											*7)
	0230-20400	Rear Wheel Adjusting Plate(							1	1					1	1			*8)
9	89-1113-060143	Hexagonal Bolt(8T) M6*14					4	4	4	4	2	2	2	2	2	2	2	2	*18)
	<b>89-1390-060143</b>	<b>Welded Bolt M6*14</b>					<b>4</b>	<b>4</b>	<b>4</b>	<b>4</b>	<b>2</b>	<b>2</b>	<b>2</b>	<b>2</b>	<b>2</b>	<b>2</b>	<b>2</b>	<b>2</b>	<b>*1) *17)</b>
10	89-1541-060003	Hexagonal Nut(SW) M6					4	4	4	4	2	2	2	2	2	2	2	2	
11	80-1022-745-00	Front Wheel Adjusting Plate					2	2											*7)
11a	0230-20300	Front Wheel Adjusting Plate(							1	1									*8)
11b	0230-20200	Front Wheel Adjusting Plate(							1	1									*8)
12	89-1113-060143	Hexagonal Bolt(8T) M6*14					4	4	4	4									
13	89-1541-060003	Hexagonal Nut(SW) M6					4	4	4	4									
14	80-1020-207-10	Rear Cover Shaft	1	1	1	1	1	1	1	1	1	1	1	1	1	1	1	1	
15	80-1020-753-00	Rear Cover Spring	1	1	1	1	1	1	1	1	1	1	1	1	1	1	1	1	
16	80-1022-751-00	Rear Cover	1	1	1	1	1	1	1	1	1	1	1	1	1	1	1	1	
17-1	80-1020-705-30	Lock Arm Bracket A	1	1	1	1	1	1	1	1	1	1	1	1	1	1	1	1	*16)
<b>17-2</b>	<b>0230-60200</b>	<b>Lock Arm Bracket A</b>								<b>1</b>								<b>1</b>	<b>*15)</b>
18	89-1132-080253	Bolt & SW Assy M8*25	2	2	2	2	2	2	2	2	2	2	2	2	2	2	2	2	
19	89-1511-080043	Nut M8	2	2	2	2	2	2	2	2	2	2	2	2	2	2	2	2	
20	80-1020-707-20	Lock Arm	1	1	1	1	1	1	1	1	1	1	1	1	1	1	1	1	
21	89-2131-080002	Snap Pin 8	1	1	1	1	1	1	1	1	1	1	1	1	1	1	1	1	
22	80-1020-733-00	Front Cover Gear Case	1	1	1	1													
	80-1022-733-00	Gear Case Cover(H)						1	1	1		1	1	1	1	1	1	1	*16)
	<b>80-1022-733-10</b>	<b>Gear Case Cover(H)</b>						<b>1</b>	<b>1</b>	<b>1</b>		<b>1</b>	<b>1</b>	<b>1</b>	<b>1</b>	<b>1</b>	<b>1</b>	<b>1</b>	<b>*15)</b>
	80-1022-734-00	Gear Case Cover(K)					1				1								
23	80-1020-735-00	Rear Cover Gear Case	1	1	1	1													
24	80-1020-736-00	Rear Cover Stationary Plate	1	1	1	1													
25	89-1161-050163	Cross Recessed Tapping Sc	2	2	2	2													
26	80-1024-952-00	Spacer 6*10									1	1	1	1	1	1	1	1	
27	83-1515-148-00	Tapping Bolt M6*22									1	1	1	1	1	1	1	1	
28	89-1133-100503	Bolt & PW SW Assy M10*50	3				3				3								*2)
29-1	83-1020-116-00	Bolt 5/16-24*45UNF (H)		2	2	2		2	2	2		2	2	2	2	2	2	2	*3) *4)
29-2	83-1022-116-00	Bolt 5/16-24*38UNF (H)		1	1	1		1	1	1		1	1	1	1	1	1	1	*3) *4) *8)
30	89-1750-080003	Spring Washer 8 (H)		2	3	3		2	3	3		2	2	3	3	3	3	3	*3) *4)
31	80-1010-789-00	Engine Setting Bolt (H)		1	1	1		1	1	1		1	1	1	1	1	1	1	*3) *4)
32	89-1750-100003	Spring Washer 10(H)		1	1	1		1	1	1		1	1	1	1	1	1	1	*3) *4)
33	89-1711-100003	Washer 10(H)		1	1	1		1	1	1		1	1	1	1	1	1	1	*3) *4)
<b>34-1</b>	<b>80-1020-721-00</b>	<b>HONDA Engine Stay (H)</b>		<b>1</b>	<b>1</b>			<b>1</b>	<b>1</b>	<b>1</b>		<b>1</b>	<b>1</b>	<b>1</b>	<b>1</b>	<b>1</b>	<b>1</b>	<b>1</b>	<b>*3)*4)*15)</b>
<b>34-2</b>	<b>0230-21100</b>	<b>HONDA Engine Stay CMP (H)</b>				1				1								1	<b>*1)*10)*16)</b>
35	83-1020-148-00	Tapping Bolt M6*14(H)		2	2	2		2	2	2		2	2	2	2	2	2	2	*3) *4)
36	83-1310-191-00	Nut M8(H)		1	1	1		1	1	1		1	1	1	1	1	1	1	*3) *4)

Fig 3 Safety Cover

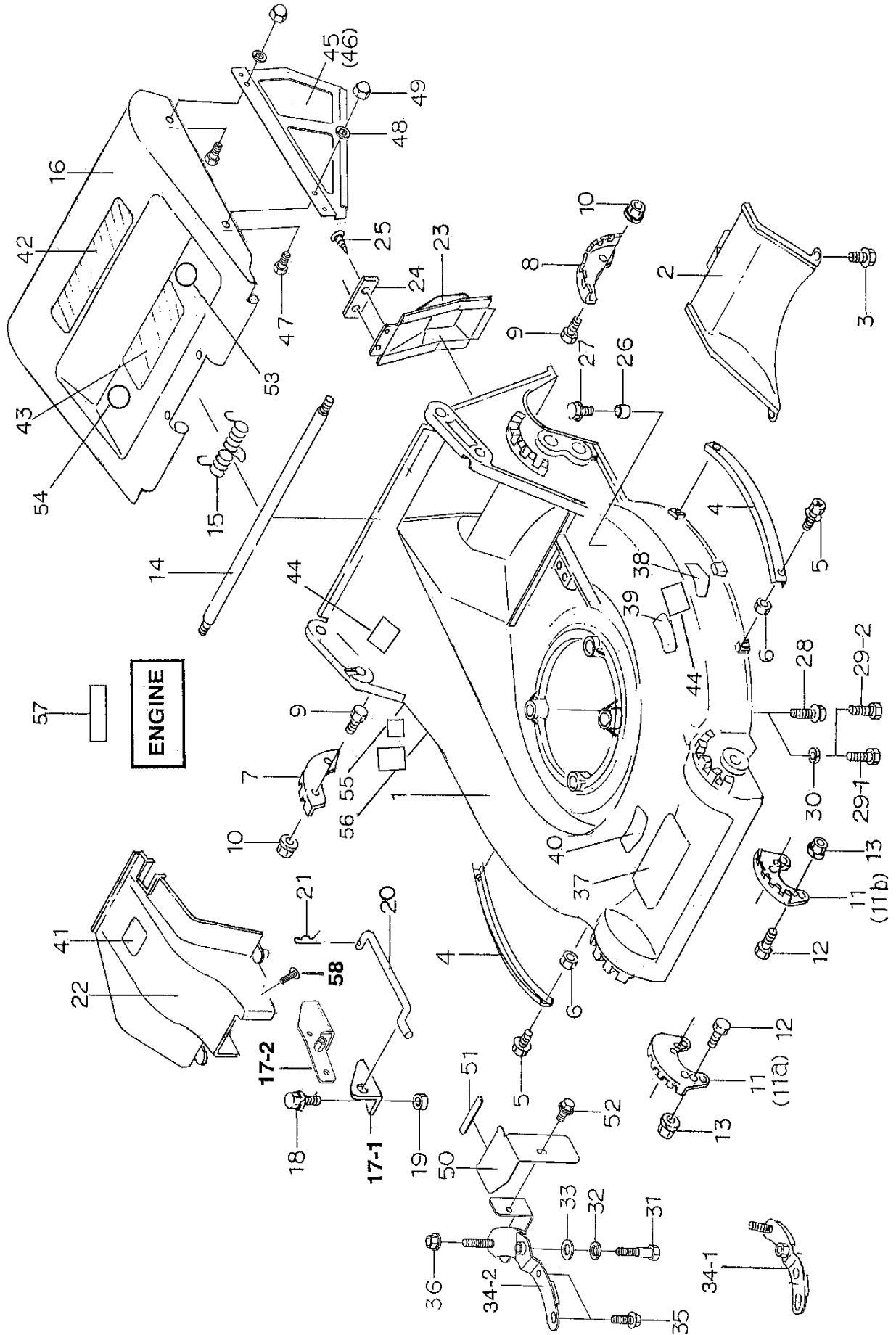

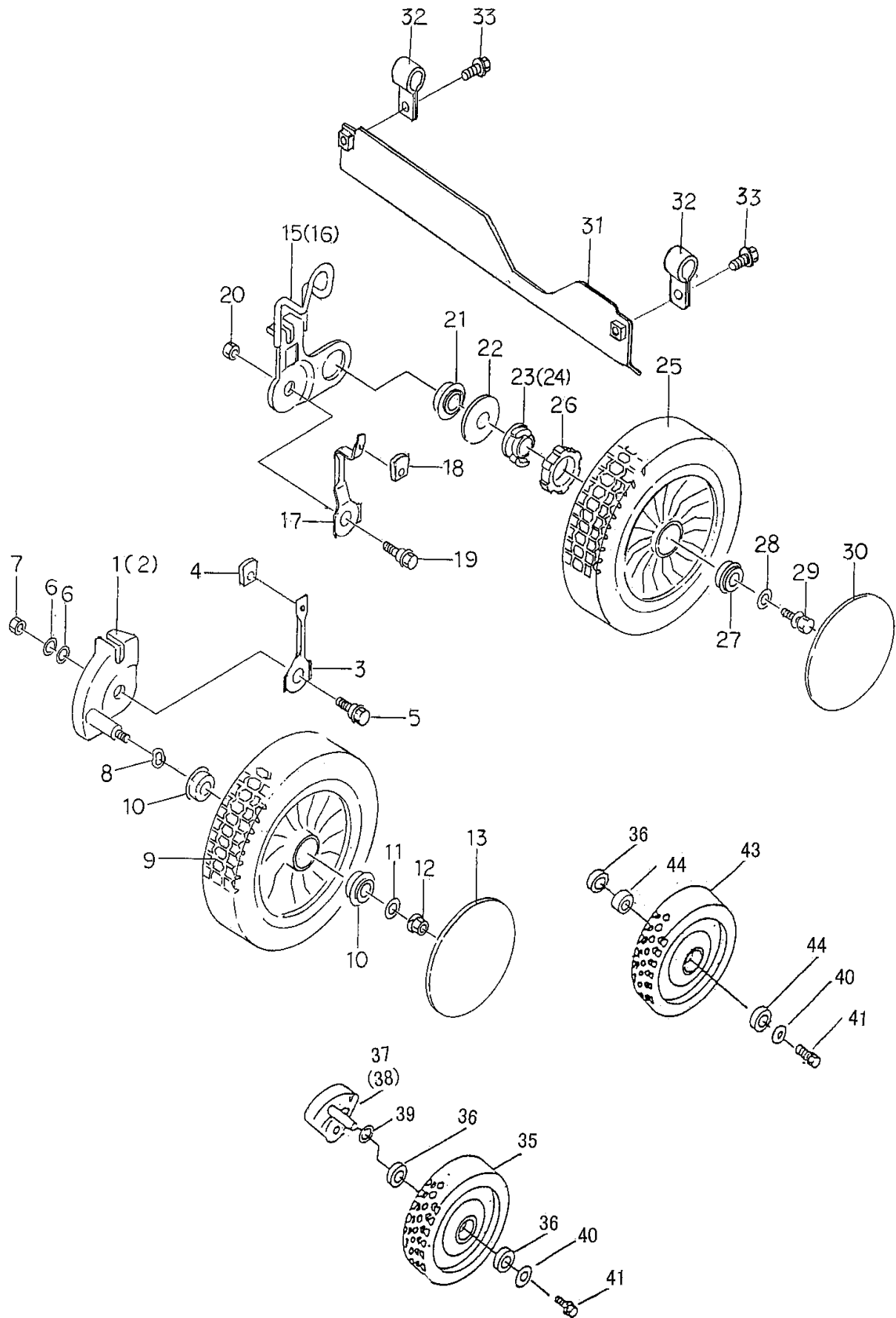

**Fig 3 Safety Cover**

Ref.	Parts No.	Parts Name	C2 (2Action Type)												Remarks	
			GR481				GR531				GR532					
			D	D	C	C2	D	D	C	C2	D	D	DT	C		C2
			FC 150	GXV 120	GXV 120	GXV 120	FC 150	GXV 160	GXV 160	GXV 160	FC 150	GXV 160	GXV 160	GXV 160		GXV 160
37	80-1020-902-00	Label (Large)	1	1	1	1	1	1	1	1	1	1		1	1	
38	80-1020-926-00	Danger Label	2	2	2	2	2	2	2	2	2	2	2	2	2	
39	80-1020-907-00	Step Label	1	1	1	1										
40	80-1020-928-00	Notice Label (Plug)	1	1	1	1	1	1	1	1	1	1	1	1	1	
41	80-1022-909-00	Notice Label (Cover)	1	1			1	1			1	1	1			*9)
42	80-1020-929-00	Notice Label (Cover)	1	1			1	1			1	1	1			*9)
43	80-1484-A47-00	Label, Caution	1	1	1		1	1	1		1	1	1	1	1	*9)
	0223-76100	Label, Caution				1				1					1	*1) *10)
44	80-1488-926-00	(13062)	1	1	1		1	1	1		1	1	1	1	1	*9)
	80-1488-926-10	(13062)				2				2					2	*1) *10)
45	80-1020-754-20	Side Plate(Left)	1	1	1	1	1	1	1	1	1	1	1	1	1	
46	80-1020-755-20	Side Plate(Right)	1	1	1	1	1	1	1	1	1	1	1	1	1	
47	89-1111-060102	Hexagonal Bolt M6*10	4	4	4	4	4	4	4	4	4	4	4	4	4	
48	89-1750-060003	Spring Washer 6	4	4	4	4	4	4	4	4	4	4	4	4	4	
49	89-1571-060043	Cap Nut M6	4	4	4	4	4	4	4	4	4	4	4	4	4	
50	0230-60100	Shaft Cover 53H								1					1	*10) *16)
	<b>0230-60110</b>	<b>Shaft Cover 53H</b>								<b>1</b>					<b>1</b>	<b>*15)</b>
	0223-60100	Shaft Cover 48H				1										*10)
51	0230-70800	Rubber L=50				1				1					1	*10) *16)
	0230-70800	Rubber L=50				1										
52	89-1139-060163	M6*16				1				1					1	*10)
53	0215-83200	Label, Protection Equipment				1				1					1	*10)
54	0223-72900	Attention Mark for Slope				1				1					1	*10)
55	80-1010-933-00	Label, CE	1	1	1	1	1	1	1	1	1	1	1	1	1	
56	80-1010-932-00	Label, Noise 96db	1	1	1	1										
	80-1020-932-00	Label, Noise 100db					1	1	1	1	1	1	1	1	1	*20)
	<b>80-1020-933-00</b>	<b>Label, Noise 98db</b>					<b>1</b>	<b>1</b>	<b>1</b>	<b>1</b>	<b>1</b>	<b>1</b>	<b>1</b>	<b>1</b>	<b>1</b>	<b>*19)</b>
57	83-1415-909-00	Sticker for Engine(Z18-6)	1	1	1		1	1	1		1	1	1	1	1	*9)
	0223-76200	Sticker for Engine				1				1					1	*1)*10)*20)
	<b>0214-72100</b>	<b>Sticker for Engine</b>				<b>1</b>				<b>1</b>					<b>1</b>	<b>*1)*10)*19)</b>
<b>58</b>	<b>89-1144-060163</b>	<b>Hexagonal Bolt with Cross</b>						<b>2</b>	<b>2</b>	<b>2</b>		<b>2</b>	<b>2</b>	<b>2</b>	<b>2</b>	<b>*15)</b>

MEMO

Fig 4 Wheel (GR481/GR531)



**Fig 4 Wheel (GR481/GR531)**

Ref.	Parts No.	Parts Name	C2 (2Action Type)												Remarks		
			GR481				GR531				GR532						
			D	D	C	C2	D	D	C	C2	D	D	DT	C		C2	
			FC 150	GXV 120	GXV 120	GXV 120	FC 150	GXV 160	GXV 160	GXV 160	FC 150	GXV 160	GXV 160	GXV 160		GXV 160	
1	80-1021-404-10	Front Wheel Arm (L)	1	1	1	1	1	1	1	1							
2	80-1021-405-10	Front Wheel Arm (R)	1	1	1	1	1	1	1	1							
3	80-1020-424-10	Front Wheel Arm Stopper	2	2	2	2											
	80-1022-424-00	Front Wheel Arm Stopper					2	2	2	2							
4	80-1020-426-10	Adjuster Grip	2	2	2	2	2	2	2	2							
5	80-1020-406-10	Arm Bolt	2	2	2	2	2	2	2	2							
6	83-1020-395-00	Washer 8*12 t0.8															For Adjustment
7	89-1551-080003	U-Nut M8	2	2	2	2	2	2	2	2							*16)
	<b>89-1551-080003</b>	<b>U-Nut M8</b>					<b>1</b>	<b>1</b>	<b>1</b>	<b>1</b>							*15)
	<b>0230-72100</b>	<b>U-Nut M8 (Thin Type)</b>					1	1	1	1							*15)(L Side)
8	83-1022-369-00	Washer 12	2	2	2	2	2	2	2	2							
9,10	80-1022-421-00	Front Wheel Assy															
9	80-1022-407-00	Front Wheel	2	2	2	2	2	2	2	2							
10	80-1022-431-00	Bearing KL-4.12	4	4	4	4	4	4	4	4							
11	89-1713-080003	Washer 8	2	2	2	2	2	2	2	2							
12	89-1541-080003	Hexagonal Nut (SW) M8	2	2	2	2	2	2	2	2							
13	80-1022-441-00	Wheel Cap	2	2	2	2	2	2	2	2							
15	80-1020-414-20	Rear Wheel Arm (Left)	1	1	1	1											
	80-1022-414-00	Rear Wheel Arm (Left)					1	1	1	1							
16	80-1020-415-20	Rear Wheel Arm (Right)	1	1	1	1											
	80-1022-415-00	Rear Wheel Arm (Right)					1	1	1	1							
17	80-1022-425-00	Rear Wheel Arm Stopper	2	2	2	2	2	2	2	2							
18	80-1020-426-10	Grip	2	2	2	2	2	2	2	2							
19	80-1020-406-10	Arm Bolt	2	2	2	2	2	2	2	2							
20	89-1551-080003	U-Nut M8	2	2	2	2	2	2	2	2							
21	83-1020-987-00	Bearing ND-0.2	2	2	2	2	2	2	2	2							
22	80-1020-433-00	Coned Disc Spring	2	2	2	2	2	2	2	2							
23	80-1020-458-00	Ratchet Assembly (Left)	1	1	1	1	1	1	1	1							
24	80-1020-459-00	Ratchet Assembly (Right)	1	1	1	1	1	1	1	1							
25-27	80-1022-422-00	Rear Wheel Assy															
25	80-1022-408-00	Rear Wheel	2	2	2	2	2	2	2	2							
26	80-1020-409-00	Clutch Guide	2	2	2	2	2	2	2	2							
27	80-1022-432-00	Bearing KL-4.15	2	2	2	2	2	2	2	2							
28	89-1713-080003	Washer 8	2	2	2	2	2	2	2	2							
29	89-1132-080203	Bolt & SW Assy M8*20	2	2	2	2	2	2	2	2							
30	80-1022-441-00	Wheel Cap	2	2	2	2	2	2	2	2							
31	80-1020-792-00	Flapper			1	1			1	1							*8)
32	80-1020-793-10	Flapper Setting			2	2			2	2							*8)
33	89-1133-060163	Bolt & PW SW Assy M6*16			2	2			2	2							*8)
35-36	80-1020-481-00	Steel Front Wheel Assy															
35	80-1020-483-00	Steel Front Wheel					2	2	2	2							
36	89-3115-062024	Bearing 6202 2RS					4	4	4	4							
37	80-1020-404-10	Front Wheel Arm (L)					1	1	1	1							
38	80-1020-405-10	Front Wheel Arm (R)					1	1	1	1							
39	83-1020-359-00	Washer 16					2	2	2	2							
40	83-1415-344-00	Washer 9*22*2.0					4	4	4	4							
41	89-1132-080203	Hexagonal Bolt (SW) M8*20					4	4	4	4							
43-45	80-1020-482-00	Steel Rear Wheel Assy															
43	80-1020-484-00	Steel Rear Wheel					2	2	2	2							
44	89-3115-062024	Bearing 6202 2RS					4	4	4	4							
45	80-1020-486-00	Collar					2	2	2	2							

Fig 4 Wheel (GR532)

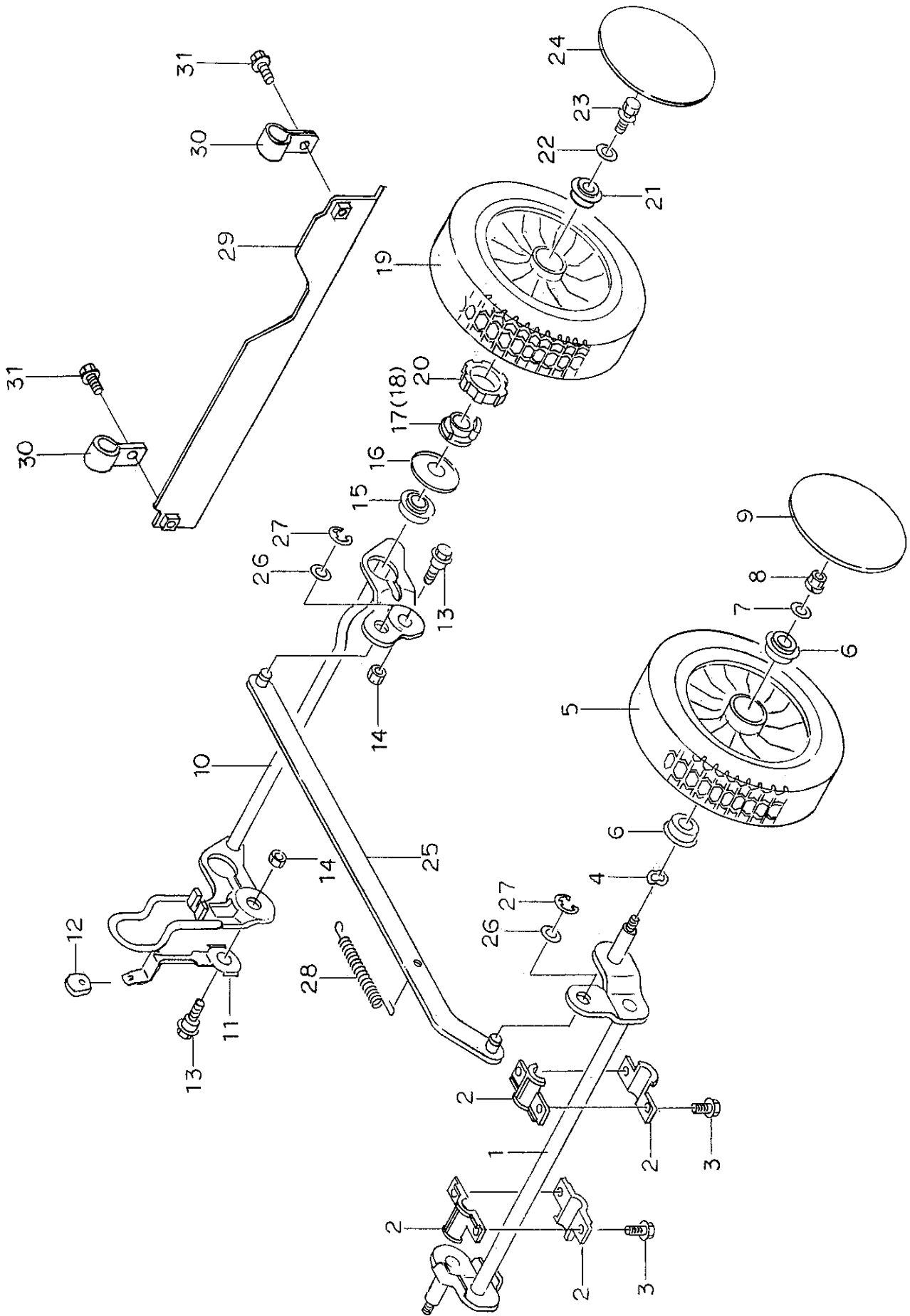
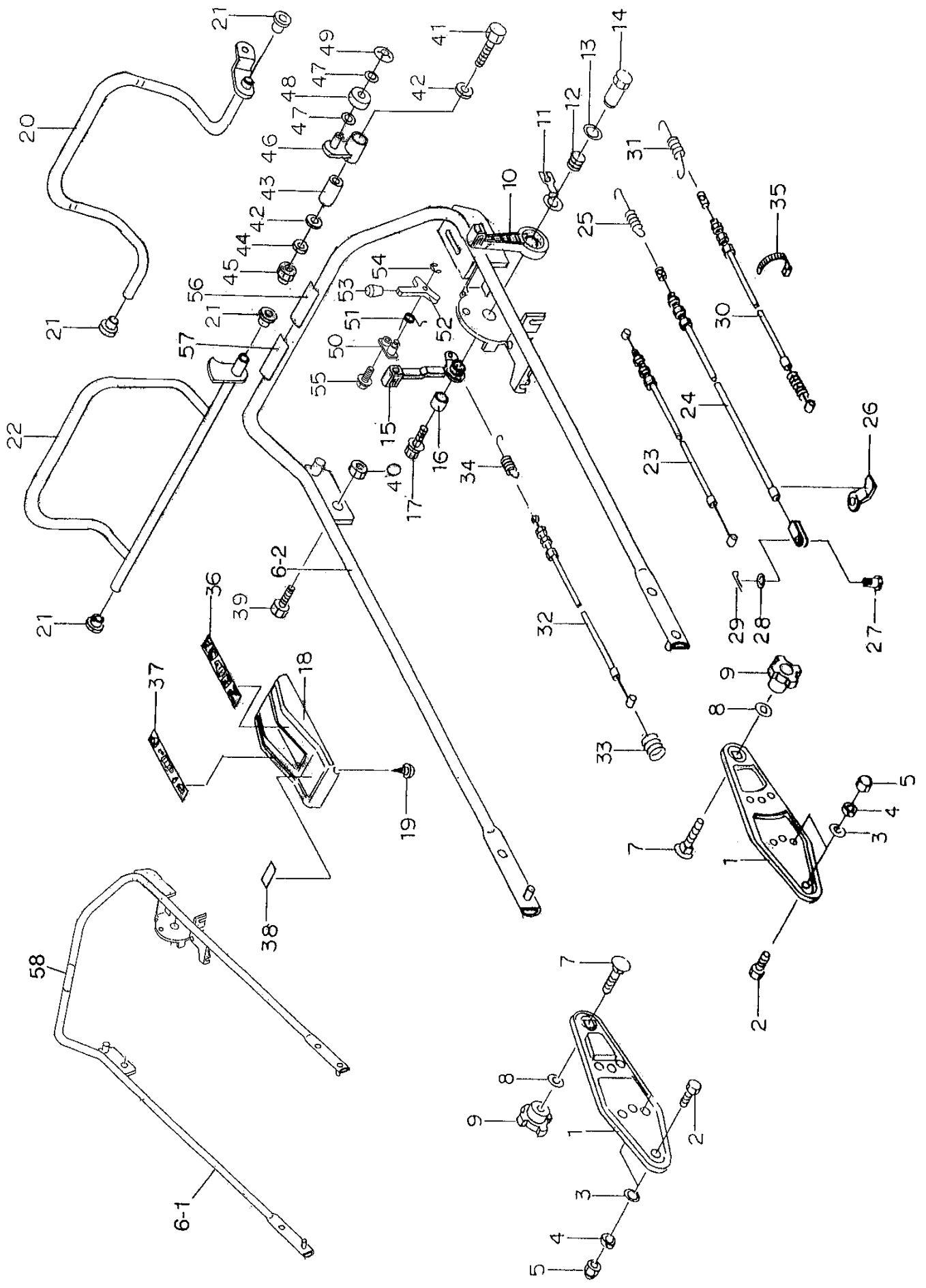

**Fig 4 Wheel (GR532)**

Ref.	Parts No.	Parts Name	C2 (2Action Type)												Remarks				
			GR481				GR531				GR532								
			D	D	C	C2	D	D	C	C2	D	D	DT	C		C2			
			FC	GXV	GXV	GXV	FC	GXV	GXV	GXV	FC	GXV	GXV	GXV		GXV			
	150	120	120	120	150	160	160	160	150	160	160	160	160						
1	80-1023-405-00	Front Wheel Arm												1	1	1	1	1	
2	80-1023-742-00	Arm Bush												4	4	4	4	4	
3	83-1020-148-00	Tapping Bolt M6*14												4	4	4	4	4	
4	83-1022-369-00	Washer 12												2	2	2	2	2	
5-6	80-1022-421-00	Front Wheel Assy																	
5	80-1022-407-00	Front Wheel												2	2	2	2	2	
6	80-1022-431-00	Bearing KL-4.12												4	4	4	4	4	
7	89-1713-080003	Washer 8												2	2	2	2	2	
8	89-1541-080003	Hexagonal Nut (SW) M8												2	2	2	2	2	
9	80-1022-441-00	Wheel Cap												2	2	2	2	2	
10	80-1023-415-00	Rear Wheel Arm												1	1	1	1	1	
11	80-1022-425-00	Rear Wheel Arm Stopper												1	1	1	1	1	
12	80-1020-426-10	Adjuster Grip												1	1	1	1	1	
13	80-1020-406-10	Arm Bolt												2	2	2	2	2	
14	89-1551-080003	U-Nut M8												2	2	2	2	2	
15	83-1020-987-00	Bearing ND-0.2												2	2	2	2	2	
16	80-1020-433-00	Coned Disc Spring												2	2	2	2	2	
17	80-1020-458-00	Ratchet Assembly (Left)												1	1	1	1	1	
18	80-1020-459-00	Ratchet Assembly (Right)												1	1	1	1	1	
19-21	80-1022-422-00	Rear Wheel Assy																	
19	80-1022-408-00	Rear Wheel												2	2	2	2	2	
20	80-1020-409-00	Clutch Guide												2	2	2	2	2	
21	80-1022-432-00	Bearing KL-4.15												2	2	2	2	2	
22	89-1713-080003	Washer 8												2	2	2	2	2	
23	89-1132-080203	Bolt & SW Assy M8*20												2	2	2	2	2	
24	80-1022-441-00	Wheel Cap												2	2	2	2	2	
25	80-1023-416-00	Translation Bar												1	1	1	1	1	
26	89-1713-100003	Washer 10												2	2	2	2	2	
27	89-2521-000083	Stopper 8(E-type)												2	2	2	2	2	
28	80-1023-417-00	Translation Spring												1	1	1	1	1	
29	0222-30100	Flapper CMP															1	1	*8)
30	80-1020-793-10	Flapper Setting															2	2	*8)
31	89-1133-060163	Bolt & PW SW Assy M6*16															2	2	*8)

MEMO

Fig 5 Handle



**Fig 5 Handle**

Ref.	Parts No.	Parts Name	C2 (2Action Type)												Remarks	
			GR481				GR531				GR532					
			D	D	C	C2	D	D	C	C2	D	D	DT	C		C2
			FC 150	GXV 120	GXV 120	GXV 120	FC 150	GXV 160	GXV 160	GXV 160	FC 150	GXV 160	GXV 160	GXV 160		GXV 160
1	80-1022-201-00	Handle Setting	2	2	2	2	2	2	2	2	2	2	2	2	*14)	
	<b>0230-10600</b>	<b>Handle Setting</b>				<b>2</b>				<b>2</b>				<b>2</b>	<b>*13)</b>	
2	89-1113-080253	Bolt 8T M8*25	2	2	2	2	2	2	2	2	2	2	2	2		
3	89-1711-080003	Washer 8	4	4	4	4	4	4	4	4	4	4	4	4		
4	89-1750-080003	Spring Washer 8	4	4	4	4	4	4	4	4	4	4	4	4		
5	89-1571-080043	Cap Nut M8	4	4	4	4	4	4	4	4	4	4	4	4		
6-1	80-1022-211-00	Handle D	1	1	1		1	1	1		1	1	1	1	*9)	
6-2	0230-10200	Handle C				1				1				1	*10)	
7	89-1412-080403	Bolt M8*40	2	2	2	2	2	2	2	2	2	2	2	2		
8	89-1711-080003	Washer 8	2	2	2	2	2	2	2	2	2	2	2	2		
9	80-1020-228-10	Knob Nut M8	2	2	2	2	2	2	2	2	2	2	2	2		
10	80-1020-261-00	Throttle Lever (K)	1				1				1				*2)	
	80-1020-265-00	Throttle Lever (H)		1	1	1		1	1	1		1	1	1	*3) *4)	
11	80-1020-264-00	Washer	1	1	1	1	1	1	1	1	1	1	1	1		
12	80-1020-263-00	Lever Shaft Spring	1	1	1	1	1	1	1	1	1	1	1	1		
13	89-1711-120003	Washer 13*21	1	1	1	1	1	1	1	1	1	1	1	1		
14	80-1020-262-00	Lever Shaft	1	1	1	1	1	1	1	1	1	1	1	1		
15	80-1020-260-00	Change Lever														
	80-1022-260-00	Change Lever	1	1	1	1	1	1	1	1	1	1	1	1	*1)	
16	80-1020-270-00	Inner Collar	1	1	1	1	1	1	1	1	1	1	1	1		
17	89-1133-080303	Bolt & PW SW Assy M8*30	1	1	1	1	1	1	1	1	1	1	1	1		
18	80-1020-231-00	Control Case	1	1	1	1	1	1	1	1	1	1	1	1		
19	89-1161-050123	Tapping Screw 5*12	2	2	2	2	2	2	2	2	2	2	2	2		
20	80-1022-242-00	Driving Lever	1	1	1	1	1	1	1	1	1	1	1	1		
21	80-1020-243-00	Driving Lever, Metal	4	4	4	4	4	4	4	4	4	4	4	4		
22	80-1022-252-00	Blade Lever	1	1	1	1	1	1	1	1	1	1	1	1		
23	83-1024-952-00	Throttle Wire V(K)	1				1				1				*2)	
	83-1022-955-10	Throttle Wire (H)		1	1	1		1	1	1		1	1	1	*3) *4) *14)	
	<b>83-1020-955-00</b>	<b>Throttle Wire (H)</b>				<b>1</b>				<b>1</b>				<b>1</b>	<b>*13)</b>	
24	83-1024-945-00	Blade Wire V	1	1	1	1	1	1	1	1	1	1	1	1	*14)	
	<b>83-1021-945-00</b>	<b>Blade Wire V</b>				<b>1</b>				<b>1</b>				<b>1</b>	<b>*13)</b>	
25	80-1021-968-10	Blade Spring VB	1	1	1	1	1	1	1	1	1	1	1	1		
26	80-1010-717-00	Blade Wire Setting	1	1	1	1	1	1	1	1	1	1	1	1		
27	89-2181-060162	Pin 6*16	1	1	1	1	1	1	1	1	1	1	1	1		
28	89-1711-060002	Washer 6	1	1	1	1	1	1	1	1	1	1	1	1		
29	89-2120-200152	Split Pin 2*15	1	1	1	1	1	1	1	1	1	1	1	1		
30	83-1024-932-00	Driving Wire V	1	1	1	1	1	1	1	1	1	1	1	1	*14)	
	<b>83-1020-932-00</b>	<b>Driving Wire V</b>				<b>1</b>				<b>1</b>				<b>1</b>	<b>*13)</b>	
31	80-1022-966-10	Driving Clutch Spring	1	1	1	1	1	1	1	1	1	1	1	1		
32	83-1024-936-00	Driving Change Wire V	1	1	1	1	1	1	1	1	1	1	1	1	*14)	
	<b>83-1020-936-00</b>	<b>Driving Change Wire V</b>				<b>1</b>				<b>1</b>				<b>1</b>	<b>*13)</b>	
33	80-1020-969-00	Change Return Spring	1	1	1	1	1	1	1	1	1	1	1	1		
34	80-1020-967-00	Change Spring	1	1	1	1	1	1	1	1	1	1	1	1		
35	83-1415-718-00	Wire Band	2	2	2	2	2	2	2	2	2	2	2	2		
36	80-1020-911-00	Throttle Label (K)	1				1				1				*2)	
	80-1020-911-10	Throttle Label (K)													*1)	
	80-1020-913-00	Throttle Label (H)		1	1			1	1			1	1		*3) *4) *9)	
	80-1020-913-10	Throttle Label (H)				1				1				1	*1) *10)	
37	80-1020-912-00	Change Label	1	1	1		1	1	1		1	1	1	1	*9)	
	80-1020-912-10	Change Label				1				1				1	*1) *10)	
38	80-1020-903-00	Label (Small)														

Fig 5 Handle

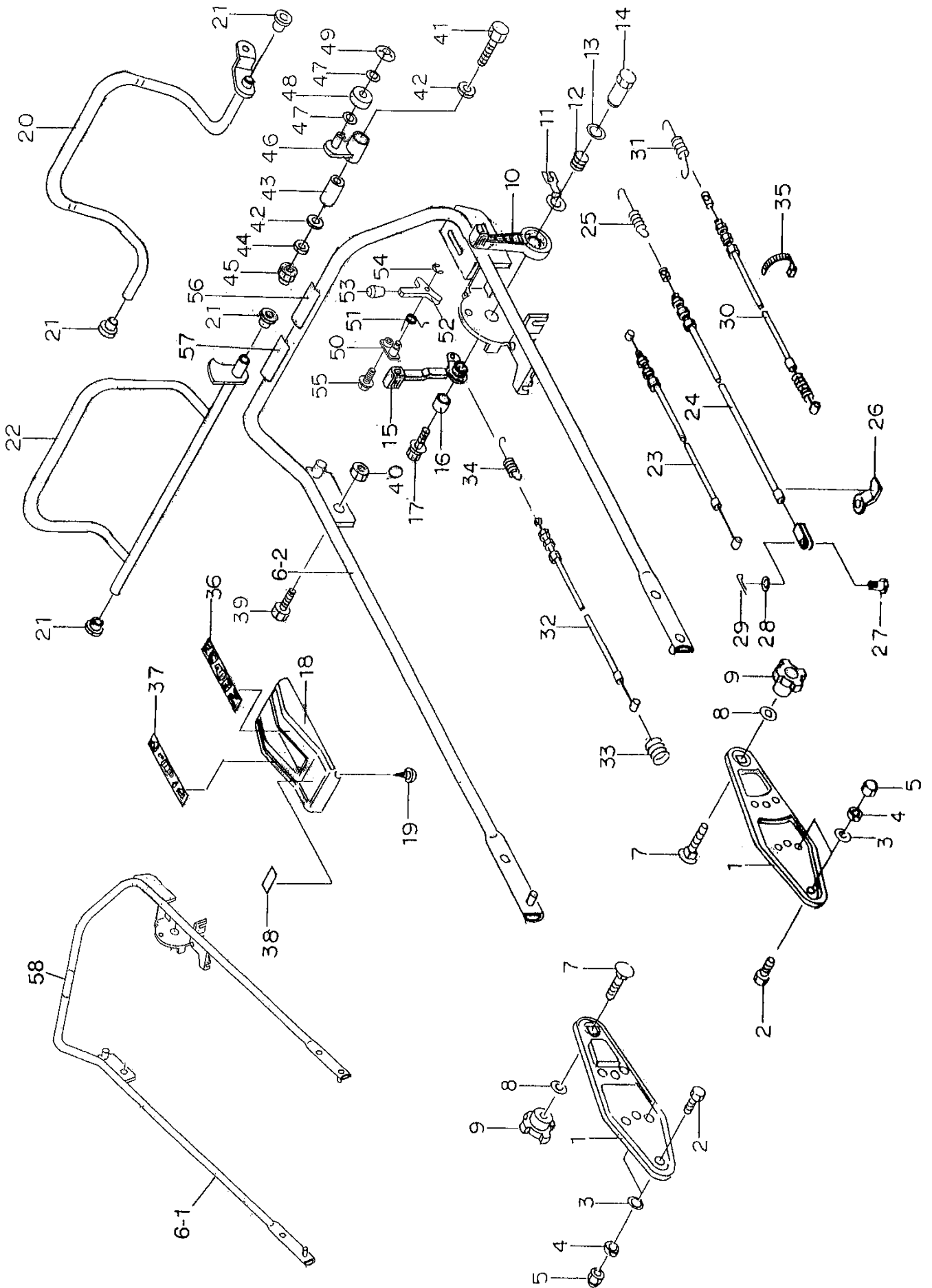



### Fig 5 Handle

Ref.	Parts No.	Parts Name	C2 (2Action Type)												Remarks	
			GR481				GR531				GR532					
			D	D	C	C2	D	D	C	C2	D	D	DT	C		C2
			FC 150	GXV 120	GXV 120	GXV 120	FC 150	GXV 160	GXV 160	GXV 160	FC 150	GXV 160	GXV 160	GXV 160		GXV 160
39	89-1113-080303	Hexagonal Bolt (8T) M8*30	1	1	1	1	1	1	1	1	1	1	1	1		
40	89-1511-080043	Hexagonal Nut M8	1	1	1	1	1	1	1	1	1	1	1	1		
41	89-1113-080503	Hexagonal Bolt (8T) M8*50	1	1	1	1	1	1	1	1	1	1	1	1		
42	89-1713-080003	Washer 8	2	2	1	1	2	2	1	1	2	2	2	1		
43	80-1022-254-00	Inner Pipe 13.8*30	1	1	1	1	1	1	1	1	1	1	1	1		
44	89-1750-080003	Spring Washer 8	1	1	1	1	1	1	1	1	1	1	1	1		
45	89-1571-080043	Cap Nut M8	1	1	1	1	1	1	1	1	1	1	1	1		
46	80-1021-252-00	Blade Wire Arm	1	1	1	1	1	1	1	1	1	1	1	1		
47	83-1020-395-00	Shim Washer 8x12x*.8	2	2	2	2	2	2	2	2	2	2	2	2		
48	80-1021-253-00	Roller	1	1	1	1	1	1	1	1	1	1	1	1	Bush 08.07	
49	83-1021-195-00	Push Nut 8	1	1	1	1	1	1	1	1	1	1	1	1		
50	0230-10500	Rock Lever Shaft CMP				1				1				1	*10)	
51	0230-70700	Spring for Rock Lever Return				1				1				1	*10)	
52	0230-10400	Rock Lever				1				1				1	*10)	
53	83-1920-425-00	Lever Grip KP204				1				1				1	*10)	
54	89-2521-000050	E Type Ring 5				1				1				1	*10)	
55	89-1139-060163	Hexagonal Bolt (PWSW) M6				1				1				1	*10)	
56	0230-71200	Blade Label				1				1				1	*10)	
57	0230-71300	Driving Label				1				1				1	*10)	
58	80-1023-A09-00	Driving & Blade Label	1	1	1		1	1	1		1	1	1	1	*9)	

MEMO

Fig 6 Blade and Bag

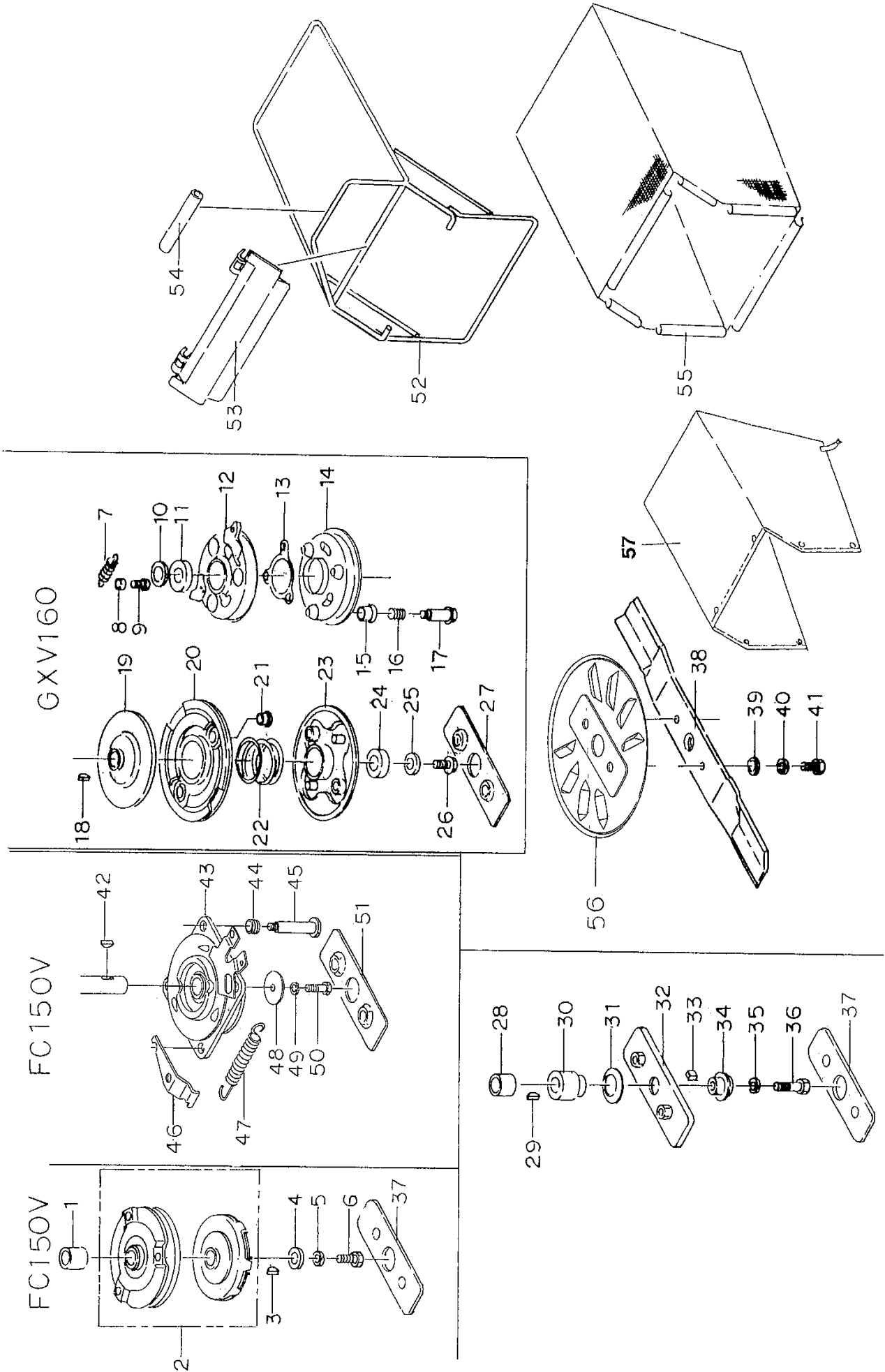

**Fig 6 Blade and Bag**

Ref.	Parts No.	Parts Name	C2 (2Action Type)													Remarks				
			GR481				GR531				GR532									
			D	D	C	C2	D	D	C	C2	D	D	DT	C	C2					
			FC 150	GXV 120	GXV 120	GXV 120	FC 150	GXV 160	GXV 160	GXV 160	FC 150	GXV 160	GXV 160	GXV 160	GXV 160					
1	80-1020-944-00	B.B.C. Spacer (K) 29.5L																		*2) *5)
2	80-1020-943-00	B.B.C. KIT (K)																		*2) *5)
3	80-1020-892-00	Woodruff Key 4*16																		*2)
4	83-1610-321-00	Washer 10*36*4.5																		*2) *5)
5	89-1750-100003	Spring Washer 10																		*2)
6	83-1020-118-00	Bolt 3/8-24*32UNF (K)																		*2)
7	80-1020-871-00	Clutch Return Spring (H)		2	2	2		2	2	2		2	2	2	2	2	2	2	2	*3) *4)
8	80-1020-872-00	Collar (H)		2	2	2		2	2	2		2	2	2	2	2	2	2	2	*3) *4)
9	83-1020-148-00	Tapping Bolt M6*14(H)		2	2	2		2	2	2		2	2	2	2	2	2	2	2	*3) *4)
10	80-1020-874-00	Thrust Washer (H)		1	1	1		1	1	1		1	1	1	1	1	1	1	1	*3) *4)
11	80-1020-875-00	Ball Bearing (H)		1	1	1		1	1	1		1	1	1	1	1	1	1	1	*3) *4)
12	80-1020-876-00	Blade (H) Assy		1	1	1		1	1	1		1	1	1	1	1	1	1	1	*3) *4)
13	80-1020-877-00	Ball Retainer (H)		1	1	1		1	1	1		1	1	1	1	1	1	1	1	*3) *4)
14	80-1020-878-00	Blade Disc (H) Assy		1	1	1		1	1	1		1	1	1	1	1	1	1	1	*3) *4)
15	80-1020-879-00	Bush (H)		3	3	3		3	3	3		3	3	3	3	3	3	3	3	*3) *4)
16	80-1020-881-00	Spring (H)		3	3	3		3	3	3		3	3	3	3	3	3	3	3	*3) *4)
17	80-1020-882-00	Blade Setting Bolt (H)		3	3	3		3	3	3		3	3	3	3	3	3	3	3	*3) *4)
18	80-1020-892-00	Woodruff Key 4*16		1	1	1		1	1	1		1	1	1	1	1	1	1	1	*3) *4)
19	80-1020-883-00	Drive Disc (H)		1	1	1		1	1	1		1	1	1	1	1	1	1	1	*3) *4)
20	80-1020-884-00	Driven Disc (H) Assy		1	1	1		1	1	1		1	1	1	1	1	1	1	1	*3) *4)
21	80-1020-885-00	Bush (H)		2	2	2		2	2	2		2	2	2	2	2	2	2	2	*3) *4)
22	80-1020-886-00	Clutch Spring (H)		1	1	1		1	1	1		1	1	1	1	1	1	1	1	*3) *4)
23	80-1020-887-00	Ball Control Plate (H) Assy		1	1	1		1	1	1		1	1	1	1	1	1	1	1	*3) *4)
24	80-1020-888-00	Ball Bearing (H)		1	1	1		1	1	1		1	1	1	1	1	1	1	1	*3) *4)
25	83-1020-323-00	Washer 10*30t4.5 (H)		1	1	1		1	1	1		1	1	1	1	1	1	1	1	*3) *4)
26	89-1254-100252	Flange Bolt M10*1.25*25 (H)		1	1	1		1	1	1		1	1	1	1	1	1	1	1	*3) *4)
27	80-1022-843-00	Blade Spacer 7H(H)		1				1				1	1							*3) *4)
	0230-50100	Blade Spacer 4.5H(H)			1	1			1	1						1	1			*8)
28	80-1020-808-00	Blade Bracket Spacer (K) 30L																		*2)
	80-1020-816-00	Blade Bracket Spacer (H) 20L																		*3) *4)
29	80-1020-892-00	Woodruff Key 4*16																		
30	80-1020-833-00	Blade Bracket Receiver (K)																		*2)
	80-1020-837-00	Blade Bracket Receiver (H)																		*3) *4)
31	89-1852-280001	Belleville Spring H28																		
32	80-1020-807-10	Blade Bracket																		
33	89-2151-040150	Key 4*15 (K)																		*2)
	89-2151-040090	Key 4*9 (H)																		*3) *4)
34	80-1020-835-00	Blade Bracket Stopper (K)																		*2)
	80-1020-836-00	Blade Bracket Stopper (H)																		*3) *4)
35	89-1750-100003	Spring Washer 10																		
36	83-1020-115-00	Bolt 3/8-24*50UNF (K)																		*2)
	89-1254-100402	Flange Bolt M10*1.25*40 (H)																		*3) *4)
37	80-1022-845-00	Blade Spacer 3H(K)																		*2) *5)
38	80-1010-821-10	Blade 480	1	1	1	1														
	80-1020-821-10	Blade 530						1	1	1	1	1	1	1	1	1	1	1	1	
39	89-1711-100003	Washer 10(K)	2					2					2							*2)
	89-1711-100003	Washer 10(H)																		
40	89-1750-100003	Spring Washer 10(K)	2					2					2							*2)
	89-1750-100003	Spring Washer 10(H)																		

Fig 6 Blade and Bag

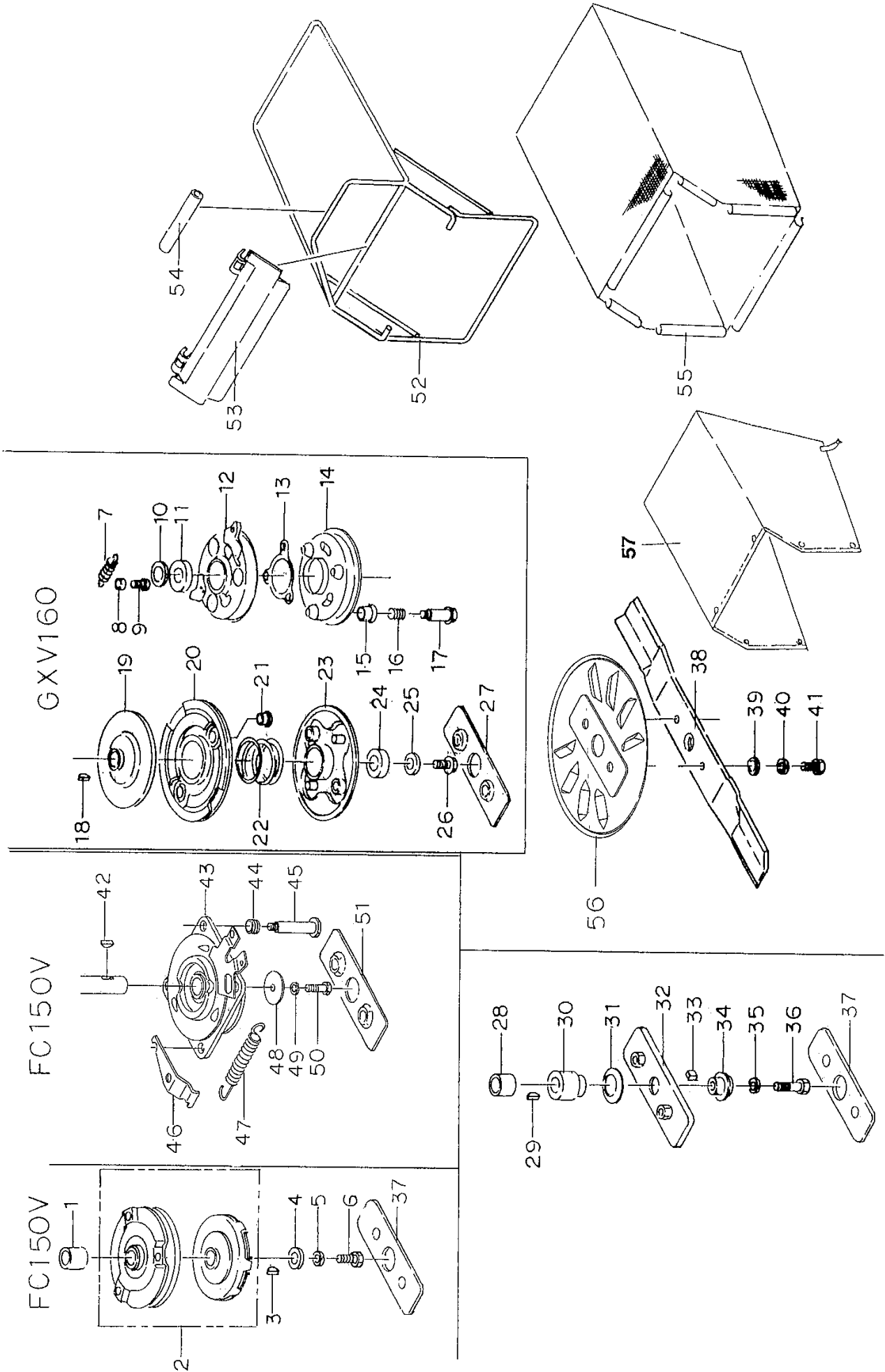

**Fig 6 Blade and Bag**

Ref.	Parts No.	Parts Name	C2 (2Action Type)												Remarks	
			GR481				GR531				GR532					
			D	D	C	C2	D	D	C	C2	D	D	DT	C		C2
			FC 150	GXV 120	GXV 120	GXV 120	FC 150	GXV 160	GXV 160	GXV 160	FC 150	GXV 160	GXV 160	GXV 160		GXV 160
41	89-1113-100253	Bolt 8T M10*25 (K)	2				2				2				*2) *5)	
	89-1113-100303	Bolt 8T M10*30 (K)														
	89-1113-100253	Bolt 8T M10*25 (H)														
	89-1254-100252	Flange Bolt M10*1.25*25 (H)		2	2	2		2	2	2		2	2	2	*3) *4)	
42	80-1020-892-00	Woodruff Key 4*16	1				1				1				*2) *6)	
43	80-1020-943-10	B.B.C Assy (K) Ogura	1				1				1				*2) *6)	
44	80-1020-958-00	B.B.C Set Spring	4				4				4				*2) *6)	
45	80-1020-959-00	B.B.C Set Bolt	4				4				4				*2) *6)	
46	80-1020-718-00	Retarn Spring Stay	1				1				1				*2) *6)	
47	80-1020-965-00	B.B.C Retarn Spring	1				1				1				*2) *6)	
48	80-1020-945-10	Washer 10*46*3.2	1				1				1				*2) *6)	
49	89-1750-100003	Spring Washer 10(K)	1				1				1				*2)	
50	83-1020-118-00	Bolt 3/8-24*32UNF (K)	1				1				1				*2)	
51	80-1022-843-00	Blade Spacer 7H	1				1				1				*2) *6)	
52	80-1022-851-00	Bag Flame	1	1	1	1	1	1	1	1	1	1	1	1		
53	80-1022-854-00	Bag Plate	1	1	1	1	1	1	1	1	1	1	1	1		
54	80-1020-854-00	Grip for Bag Frame														
55	80-1022-853-00	Bag	1	1			1	1			1	1	1		*7)	
	0230-70400	Bag C			1	1			1	1				1	*1) *8)	
	<b>80-1022-856-00</b>	<b>Bag C (with Hook)</b>													<b>(Option)</b>	
56	80-1023-861-00	BBC Cover											1		*7)	
	0222-50100	BBC Cover											1		*10)	
<b>57</b>	<b>0230-71400</b>	<b>Dustproof Cover</b>													<b>(Option)</b>	

MEMO